

iphone6 4.7



1. ALL RESISTANCE VALUES ARE IN OHMS, 0.1WATT+/-%
2. ALL CAPACITANCE VALUES ARE IN MICROFARADS.
3. ALL CRYSTALS & OSCILLATOR VALUES ARE IN HERTZ.

REV	ECN	DESCRIPTION OF REVISION	CK APPD	DATE
7	0002727241	ENGINEERING RELEASED		2014-04-18

N61 CARRIER BUILD

N61 BOM CALLOUTS

PDF PAGE CONTENTS

2	2	SOC:MAIN	N56_MLB	08/29/2013
3	3	SOC:I/OS	N56_MLB	08/29/2013
4	4	SOC:VDDCA, VDD1/2, VDD, VDD_CPU, VDD_GPU	N56_MLB	08/29/2013
5	5	SOC:GND, VDDIO18, VDDIOD, VDD_VAR_SOC	N56_MLB	08/29/2013
6	6	SOC:NAND	N56_MLB	08/29/2013
7	7	SOC:CAM, LCD, LPDP, PCIE	N56_MLB	08/29/2013
8	8	IO:BUTTON FLEX CONN	N61_MLB	08/26/2013
9	9	AUDIO:L67 CODEC (1/2)	N61_MLB	08/26/2013
10	10	AUDIO:L67 CODEC (2/2)	N61_MLB	08/26/2013
11	11	CAMERA:FRONT FLEX CONN	N61_MLB	08/26/2013
12	12	POWER:ADI (1/2)	N56_MLB	08/29/2013
13	13	POWER:ADI (2/2)	N56_MLB	08/29/2013
14	14	POWER:TIGRIS, VIBE DRIVER	N61_MLB	08/21/2013
15	15	DISPLAY:CHESTNUT, BACKLIGHT DRIVER	N61_MLB	08/26/2013
16	16	AUDIO:SPKR AMP, STROBE	N61_MLB	08/26/2013
17	17	IO:TRISTAR2	N61_MLB	08/26/2013
18	18	IO:DOCK FLEX CONN	N61_MLB	08/26/2013
19	19	SENSORS:COMPASS	N61_MLB	08/26/2013
20	20	DISPLAY:FLEX CONN	N61_MLB	08/26/2013
21	21	SENSORS:MESA FLEX CONN	N61_MLB	08/26/2013
22	22	SENSORS:OSCAR, CARBON, PHOS, MAGNESIUM	N61_MLB	08/26/2013
23	23	CAMERA:REAR FLEX CONN	N61_MLB	08/26/2013
24	24	TOUCH:CUMULUS, MESON	N/A	N/A
25	25	POWER:BATT CONN, TPS, PD FEATURES	N61_MLB	08/26/2013
26	26	SYSTEM:VOLTAGE PROPERTIES	N56_MLB	09/10/2013
27	27	SYSTEM:N61 SPECIFIC	N56_MLB	09/10/2013
28	28	BLANK	N56_MLB	09/10/2013
29	30	CELL:ALIASES		
30	31	AP INTERFACE & DEBUG CONNECTORS	N61_RADIO_MLB	03/24/2014
31	32	BASEBAND PMU (1 OF 2)	N61_RADIO_MLB	03/24/2014
32	33	BASEBAND PMU (2 OF 2)	N61_RADIO_MLB	03/24/2014
33	34	BASEBAND (1 OF 2)	N61_RADIO_MLB	03/24/2014
34	35	BASEBAND (1 OF 2)	N61_RADIO_MLB	03/24/2014
35	36	MOBILE DATA MODEM (2 OF 2)	N61_RADIO_MLB	03/24/2014
36	37	RF TRANSCEIVER (1 OF 3)	N61_RADIO_MLB	03/24/2014
37	38	RF TRANSCEIVER (2 OF 3)	N61_RADIO_MLB	03/24/2014
38	39	RF TRANSCEIVER (3 OF 3)	N61_RADIO_MLB	03/24/2014
39	40	QFE DCDC	N61_RADIO_MLB	03/24/2014
40	41	2G PA	N61_RADIO_MLB	03/24/2014
41	42	VERY LOW BAND PAD	N61_RADIO_MLB	03/24/2014
42	43	LOW BAND PAD	N61_RADIO_MLB	03/24/2014
43	44	MID BAND PAD	N61_RADIO_MLB	03/24/2014
44	45	HIGH BAND PAD	N61_RADIO_MLB	03/24/2014
45	46	ANTENNA SWITCH	N61_RADIO_MLB	03/24/2014
46	47	HIGH BAND SWITCH	N61_RADIO_MLB	03/24/2014
47	48	RX DIVERSITY	N61_RADIO_MLB	03/24/2014
48	49	GPS	N61_RADIO_MLB	03/24/2014
49	50	GPS	N61_RADIO_MLB	03/24/2014
50	51	ANTENNA FEEDS	N61_RADIO_MLB	03/24/2014
51	52	WIFI/BT: MODULE AND FRONT END	N61_RADIO_MLB	03/24/2014
52	53		N61_RADIO_MLB	03/24/2014
53	54	JUMPER	N61_RADIO_MLB	03/24/2014
54	55	JUMPER	N61_RADIO_MLB	03/24/2014

NAND BOM OPTIONS

PART#	QTY	DESCRIPTION	REFERENCE DESIGNATOR(S)	CRITICAL	BOM OPTION
335S0998	1	NAND, 19NM, 16GX8, MLC, PPN1.5	U0604	CRITICAL	NAND_16G
335S0993	1	NAND, 19NM, 32GX8, MLC, PPN1.5	U0604	CRITICAL	NAND_32G
335S0994	1	NAND, 19NM, 64GX8, MLC, PPN1.5	U0604	CRITICAL	NAND_64G
335S00010	1	NAND, 19NM, 128GX8, TLC, PPN1.5	U0604	CRITICAL	NAND_128G
138S0867	1	CAP, X5R, 10UF, 20%, 6.3V, 0.65MM, HRTZ, 0402	C0610, C0611, C0614, C0634	CRITICAL	NAND_16G
138S0867	1	CAP, X5R, 10UF, 20%, 6.3V, 0.65MM, HRTZ, 0402	C0613, C0633, C0610, C0611, C0614, C0634	CRITICAL	NAND_32G & NAND_64G
138S00003	1	CAP, X5R, 15UF, 20%, 6.3V, 0.65MM, HRTZ, 0402	C0613, C0633, C0610, C0611, C0614, C0634	CRITICAL	NAND_128G

ALTERNATE NAND BOM OPTIONS

PART NUMBER	ALTERNATE FOR PART NUMBER	BOM OPTION	REF DES	COMMENTS:
335S0992	335S0998	ALTERNATE	J0604	TOSHIBA, NAND, 16GB
335S1038	335S0998	ALTERNATE	J0604	HYNIX, NAND, 16GB
335S1040	335S0994	ALTERNATE	J0604	HYNIX, NAND, 64GB
335S00014	335S0994	ALTERNATE	J0604	TOSHIBA, NAND, 64GB
335S00015	335S00010	ALTERNATE	J0604	TOSHIBA, NAND, 128GB
335S00009	335S0994	ALTERNATE	J0604	SANDISK, NAND, 64GB, TLC

SHIELD BOM OPTIONS

PART#	QTY	DESCRIPTION	REFERENCE DESIGNATOR(S)	CRITICAL	BOM OPTION
604-00241	1	SUBASSY, SHIELD, UPPER FRONT, N61	SH2501	CRITICAL	COMMON
604-00242	1	SUBASSY, SHIELD, LOWER FRONT, N61	SH2502	CRITICAL	COMMON
604-00243	1	SUBASSY, SHIELD, LOWER BACK, N61	SH2504	CRITICAL	COMMON
604-00244	1	SUBASSY, SA SHIELD, N61	SH2506	CRITICAL	COMMON

广西南宁功夫手机维修培训
修一切苹果 招天下学生
十年一线维修经验及教学经验

让学员们快速学会维修技术及原理分析
详情请加:
QQ: 343974077 翁老师电话: 13737083768
QQ: 344106191 王老师电话: 13737070888

SCH 051-9903
BRD 820-3486
MCO 056-6825

BOM 639-4237 (16GB, BETTER) BOM 639-00208 (16GB, BETTER, DTD)
BOM 639-5838 (32GB, BEST) BOM 639-00209 (32GB, BEST, DTD)
BOM 639-5839 (64GB, ULTRA) BOM 639-00210 (64GB, ULTRA, DTD)

BOM 639-00025 (128GB, SUPREME, TLC) BOM 639-00212 (128GB, SUPREME, TLC, DTD)

PART#	QTY	DESCRIPTION	REFERENCE DESIGNATOR(S)	CRITICAL	BOM OPTION
051-9903	1	SCH, MLB, N61	SCH	CRITICAL	?
820-3486	1	PCBF, MLB, N61	PCB	CRITICAL	?
825-6838	1	EEEE FOR 639-4237 16GB	EEEE_G16T	CRITICAL	EEEE_16G
825-6838	1	EEEE FOR 639-5838 32GB	EEEE_G16R	CRITICAL	EEEE_32G
825-6838	1	EEEE FOR 639-5839 64GB	EEEE_G16Q	CRITICAL	EEEE_64G
825-6838	1	EEEE FOR 639-00025 128GB	EEEE_G16N	CRITICAL	EEEE_128G
825-6838	1	EEEE FOR 639-00208 16GB	EEEE_F98F	CRITICAL	EEEE_16G_TDDLTE
825-6838	1	EEEE FOR 639-00209 32GB	EEEE_FQKQ	CRITICAL	EEEE_32G_TDDLTE
825-6838	1	EEEE FOR 639-00210 64GB	EEEE_FQJY	CRITICAL	EEEE_64G_TDDLTE
825-6838	1	EEEE FOR 639-00212 128GB	EEEE_FY9W	CRITICAL	EEEE_128G_TLC_TDDLTE

ALTERNATE BOM OPTIONS

PART NUMBER	ALTERNATE FOR PART NUMBER	BOM OPTION	REF DES	COMMENTS:
152S1844	152S1836	ALTERNATE	L1604	TY ALT INDUCTOR
152S1842	152S1849	ALTERNATE	L1519	TY ALT INDUCTOR
197S0392	197S0369	ALTERNATE	Y1200	ESPN ALT XTAL
197S0399	197S0369	ALTERNATE	Y1200	NDK ALT XTAL
338S1285	338S1202	ALTERNATE	U1601	L21 SPKAMP
152S2034	152S2033	ALTERNATE	1.2MM	1.00H, CYNTEC
152S00004	152S2049	ALTERNATE	1.2MM	0.47UH, CYNTEC
339S00005	339S0246	ALTERNATE	U0201	FIJI, B0, SAMSUNG
339S0247	339S0246	ALTERNATE	U0201	FIJI, B0, HYNIX
339S00006	339S0246	ALTERNATE	U0201	FIJI, B1, E
339S00007	339S0246	ALTERNATE	U0201	FIJI, B1, H
339S00008	339S0246	ALTERNATE	U0201	FIJI, B1, S
155S0773	155S0453	ALTERNATE		TY 1200HM FERRITE
118S0764	118S0717	ALTERNATE	R1309	3.92KOHM, 01005
343S0688	343S0638	ALTERNATE	U2401	CUMULUS C1, FAB4
138S00005	138S00003	ALTERNATE	C1290	15UF, 0402, HRTZL CAP
155S00011	155S00008	ALTERNATE	L1135	CMC, 90OHM, MURATA
377S0168	377S0140	ALTERNATE	DZ1113	SUPPL, TRANS, VARISTOR, MOTEC
155S0895	155S0610	ALTERNATE	FL1802, FL1803	FEED, 20, 1500M, 200M, 01005
138S0648	138S0652	ALTERNATE	C1018	CAP, 4.7UF, 20%, 6.3V, 0402, R=0.65MM
138S0657	138S0702	ALTERNATE	C1106	CAP, 4.7UF, 20%, 6V, 0402
338S00028	338S00017	ALTERNATE	J2203	CARBON, BOSCH, BMS142BC
338S00029	338S00017	ALTERNATE	J2203	CARBON, ST, AP6052AA
335S00013	335S0894	ALTERNATE	J0301	BT BK REFRON

DRAWING TITLE		SCHEM, MLB, N61	
Apple Inc.	DRAWING NUMBER	051-9903	SIZE D
	REVISION	7.0.0	
NOTICE OF PROPRIETARY PROPERTY:		BRANCH	
THE INFORMATION CONTAINED HEREIN IS THE PROPRIETARY PROPERTY OF APPLE INC. THE POSSESSOR AGREES TO THE FOLLOWING:		PAGE	1 OF 55
I TO MAINTAIN THIS DOCUMENT IN CONFIDENCE		SHEET	1 OF 54
II NOT TO REPRODUCE OR COPY IT			
III NOT TO REVEAL OR PUBLISH IT IN WHOLE OR PART			
IV ALL RIGHTS RESERVED			

FIJI: JTAG, USB, HSIC, XTAL

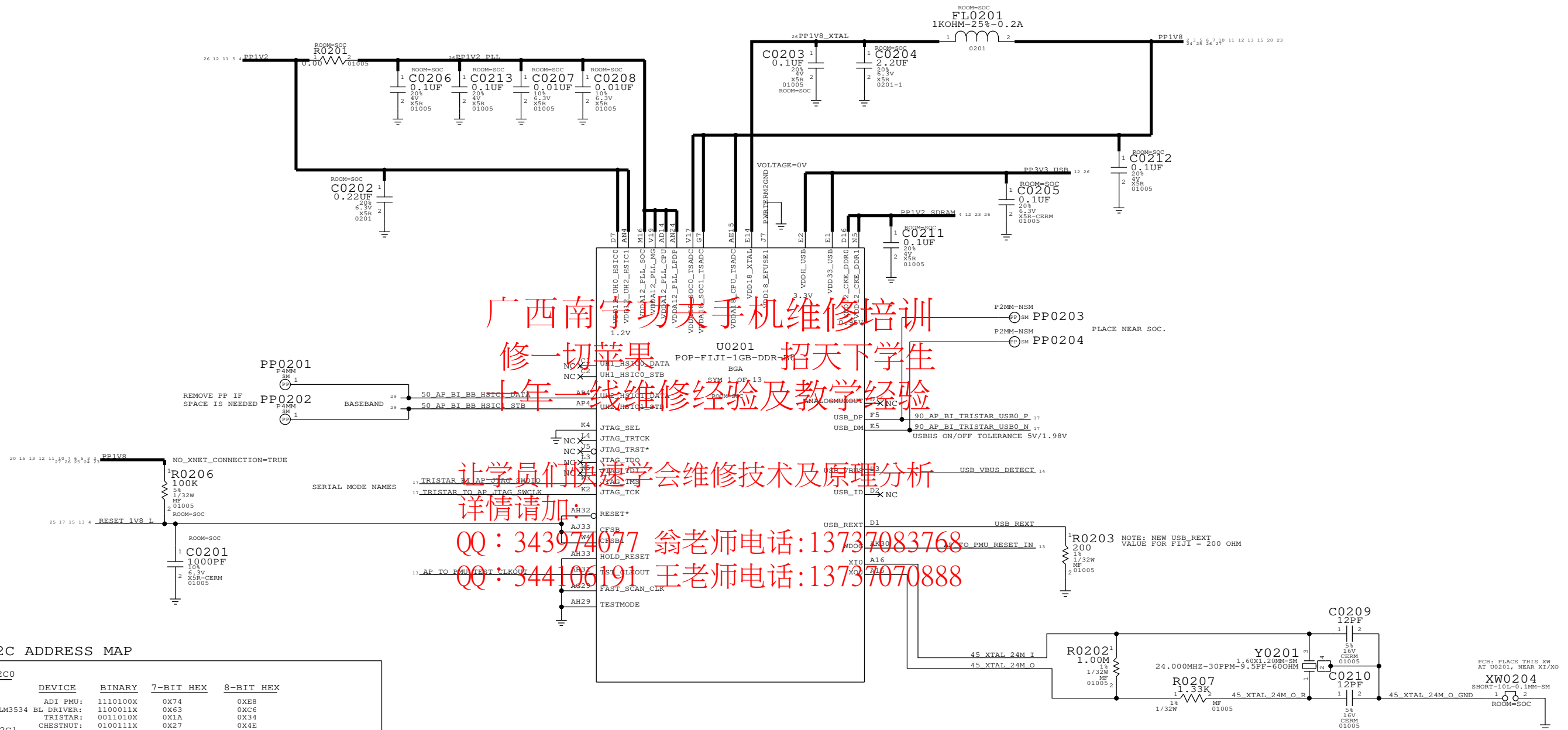

广西南宁功夫手机维修培训
修一切苹果 招天下学生
十年一线维修经验及教学经验

让学员们快速学会维修技术及原理分析
详情请加:
QQ: 343974077 翁老师电话: 13737083768
QQ: 344106191 王老师电话: 13737070888

I2C ADDRESS MAP

I2C0	DEVICE	BINARY	7-BIT HEX	8-BIT HEX
I2C0	ADI PMU:	1110100X	0X74	0XE8
	LM3534 BL DRIVER:	1100011X	0X63	0XC6
	TRISTAR:	0011010X	0X1A	0X34
	CHESTNUT:	0100111X	0X27	0X4E
I2C1	TIGRIS CHARGER:	1110101X	0X75	0XEA
	LINEAR VIBE:	1011010X	0X5A	0XB4
	CS35L19B AMP:	1000000X	0X40	0X80
	MESA EEPROM (MEMORY):	1010110X	0X56	0XAC
MESA EEPROM (ID):	1011110X	0X5E	0XBC	
I2C2	CT814 ALS:	0101001X	0X29	0X52
	DISPLAY EEPROM:	1010001X	0X51	0XA2
RCAM I2C	OPEL STROBE DRIVER:	1100011X	0X63	0XC6
	REAR FACING CAM:	0010000X	0X10	0X20
	VCM AF DRIVER:	0001100X	0X0C	0X18
FCAM I2C	FRONT FACING CAM:	0010000X	0X10	0X20

NOTE: ACCEL, GYRO, COMPASS ALL USING SPI (VIA OSCAR) FOR AP COMMUNICATION.

SYNC_MASTER=N56_MLB SYNC_DATE=08/29/2013

PAGE TITLE: SOC:MAIN

Apple Inc.

DRAWING NUMBER: 051-9903 SIZE: D

REVISION: 7.0.0

NOTICE OF PROPRIETARY PROPERTY: THE INFORMATION CONTAINED HEREIN IS THE PROPRIETARY PROPERTY OF APPLE, INC. THE POSSESSOR AGREES TO THE FOLLOWING: I TO MAINTAIN THIS DOCUMENT IN CONFIDENCE II NOT TO REPRODUCE OR COPY IT III NOT TO REVEAL OR PUBLISH IT IN WHOLE OR PART IV ALL RIGHTS RESERVED

PAGE: 2 OF 55 SHEET: 2 OF 54

FIJI: DIGITAL I/O, BOOTSTRAPPING

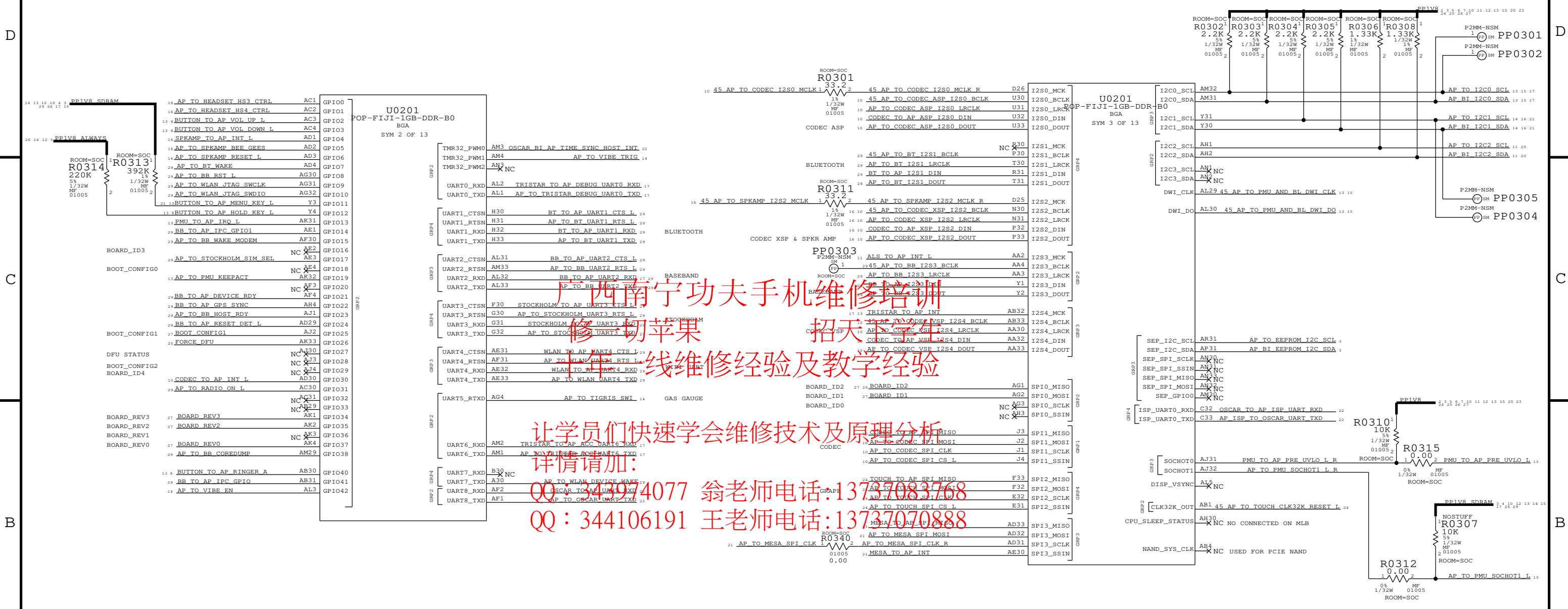

ANTI-ROLLBACK EEPROM
ONSEMI EEPROM
APN: 335S0894

REMOVED HOLD + MENU KEY
BUFFERS SINCE NOT NEEDED FOR FIJI

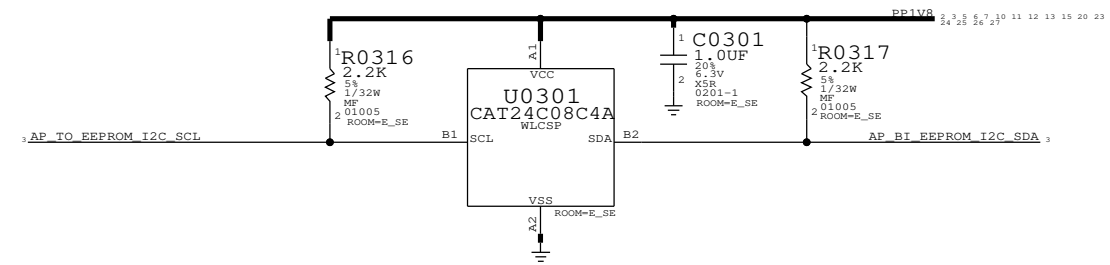

广西南宁功夫手机维修培训
招收天下学生
修一切苹果
线维修经验及教学经验
让学员们快速学会维修技术及原理分析
详情请加:
QQ: 342974077 翁老师电话: 13737083708
QQ: 344106191 王老师电话: 1373708888

Table with technical specifications and metadata including drawing number 051-9903, revision 7.0.0, and page information (3 of 55).

FIJI: VDDCA, VDD1/2, VDDQ, VDD, VDD_FIXED, VDD_CPU, VDD_GPU

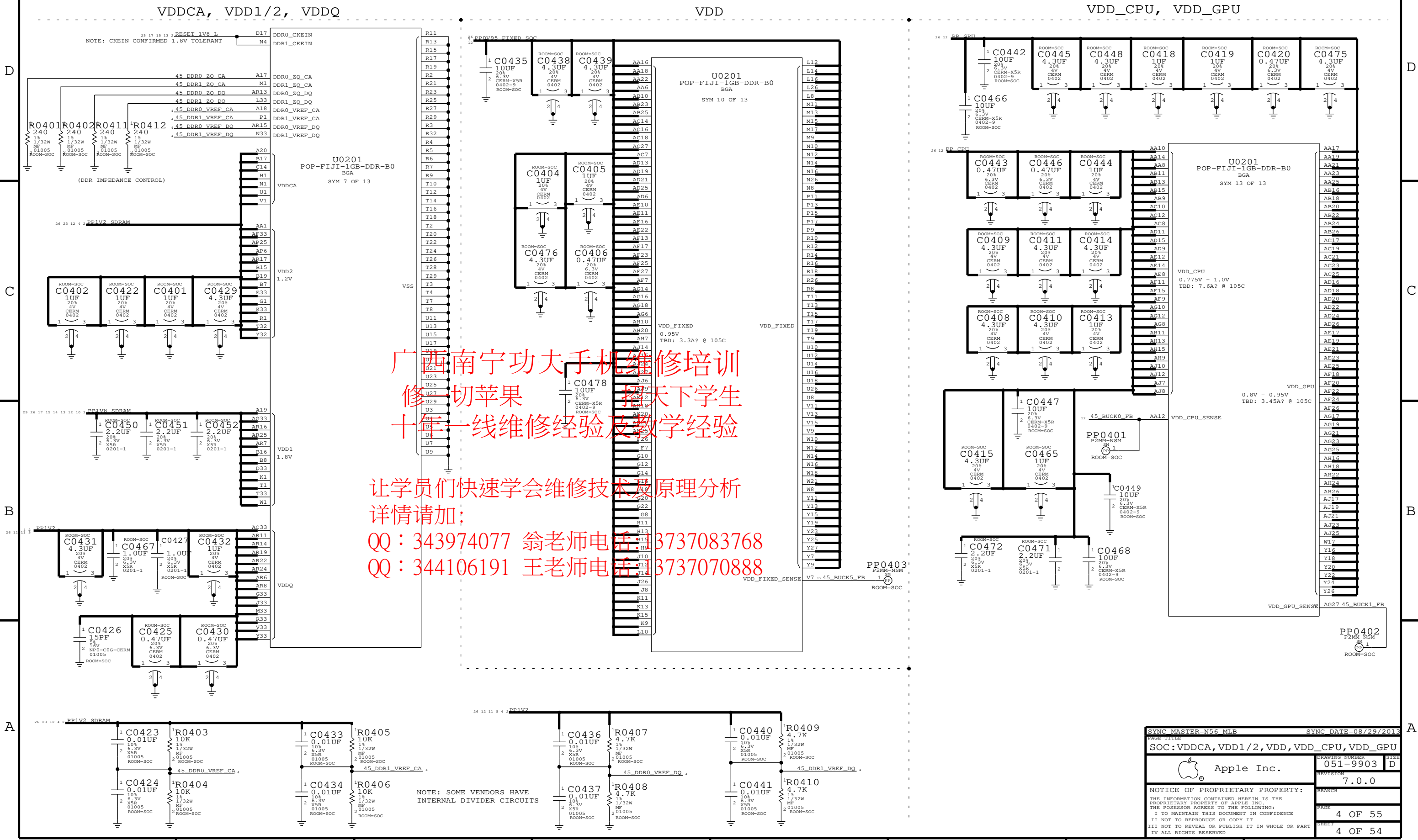

广西南宁功夫手机维修培训
修一切苹果 招天下学生
十年一线维修经验及教学经验

让学员们快速学会维修技术及原理分析
详情请加:
QQ: 343974077 翁老师电话: 13737083768
QQ: 344106191 王老师电话: 13737070888

SYNC MASTER=N56 MLB		SYNC DATE=08/29/2013	
PAGE TITLE			
SOC: VDDCA, VDD1/2, VDD, VDD_CPU, VDD_GPU			
Apple Inc.		DRAWING NUMBER	SIZE
		051-9903	D
		REVISION	
		7.0.0	
NOTICE OF PROPRIETARY PROPERTY:			
THE INFORMATION CONTAINED HEREIN IS THE PROPRIETARY PROPERTY OF APPLE INC. THE POSSESSOR AGREES TO THE FOLLOWING:			
I TO MAINTAIN THIS DOCUMENT IN CONFIDENCE			
II NOT TO REPRODUCE OR COPY IT			
III NOT TO REVEAL OR PUBLISH IT IN WHOLE OR PART			
IV ALL RIGHTS RESERVED			
		PAGE	4 OF 55
		SHEET	4 OF 54

FIJI: VDDIOD, VDDIO18, VDD_VAR_SOC

JUST A FEW GNDS

VDD_SRAM, VDD_SOC

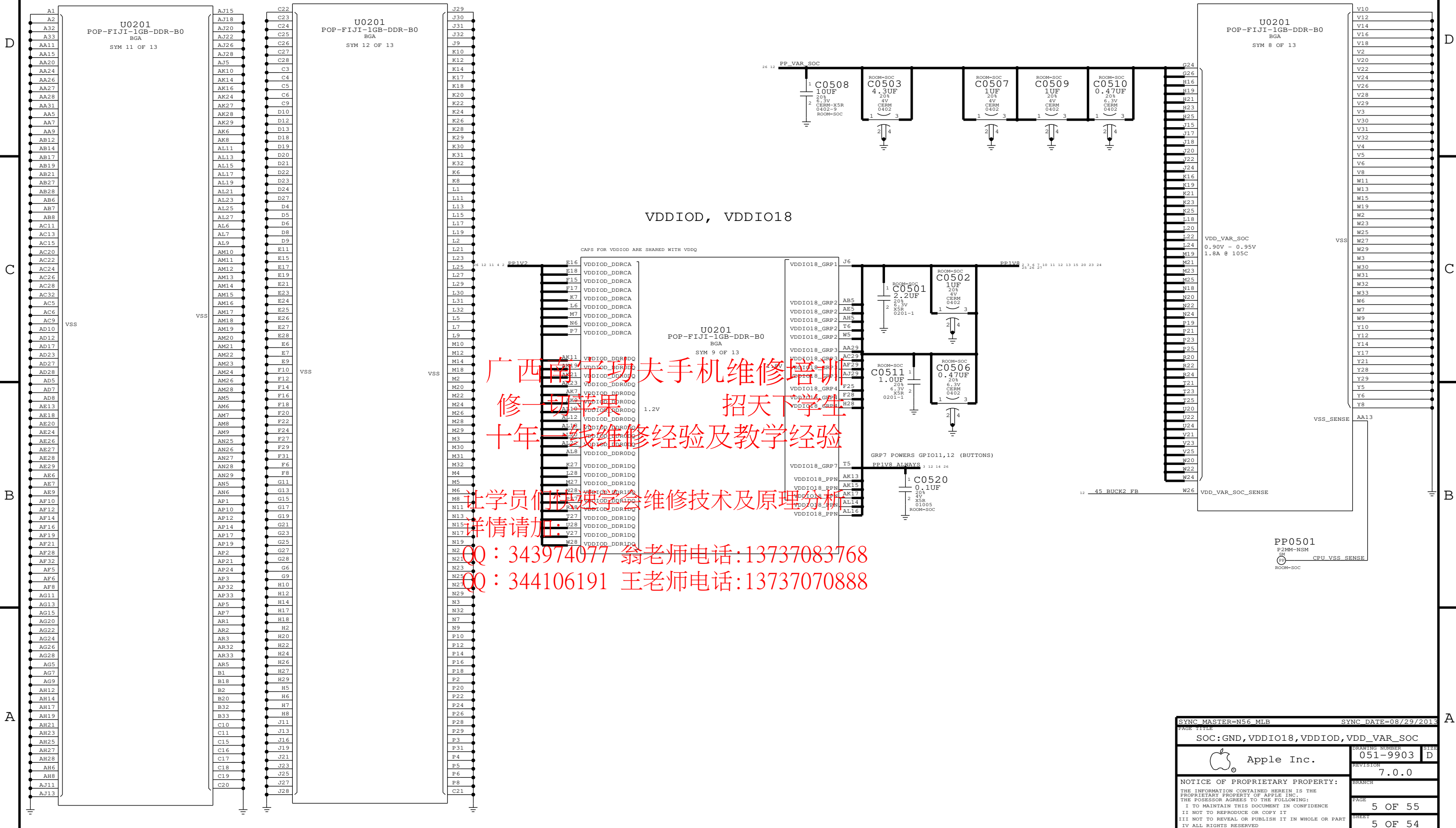

广西南宁平功夫手机维修培训
 修一切苹果手机 招天下学生
 十年一线维修经验及教学经验

让学员们快速学会维修技术及原理
 详情请加：
 QQ: 343974077 翁老师电话: 13737083768
 QQ: 344106191 王老师电话: 13737070888

SYNC_MASTER=N56_MLB		SYNC_DATE=08/29/2013	
PAGE TITLE SOC: GND, VDDIO18, VDDIOD, VDD_VAR_SOC			
Apple Inc.		DRAWING NUMBER 051-9903	SIZE D
NOTICE OF PROPRIETARY PROPERTY: THE INFORMATION CONTAINED HEREIN IS THE PROPRIETARY PROPERTY OF APPLE INC. THE POSSESSOR AGREES TO THE FOLLOWING: I TO MAINTAIN THIS DOCUMENT IN CONFIDENCE II NOT TO REPRODUCE OR COPY IT III NOT TO REVEAL OR PUBLISH IT IN WHOLE OR PART IV ALL RIGHTS RESERVED		REVISION 7.0.0	PAGE 5 OF 55
		BRANCH	SHEET 5 OF 54

FIJI: NAND + 12X17 NAND PKG

SUPPORT FOR PPN1.5 (1.8V IO) ONLY

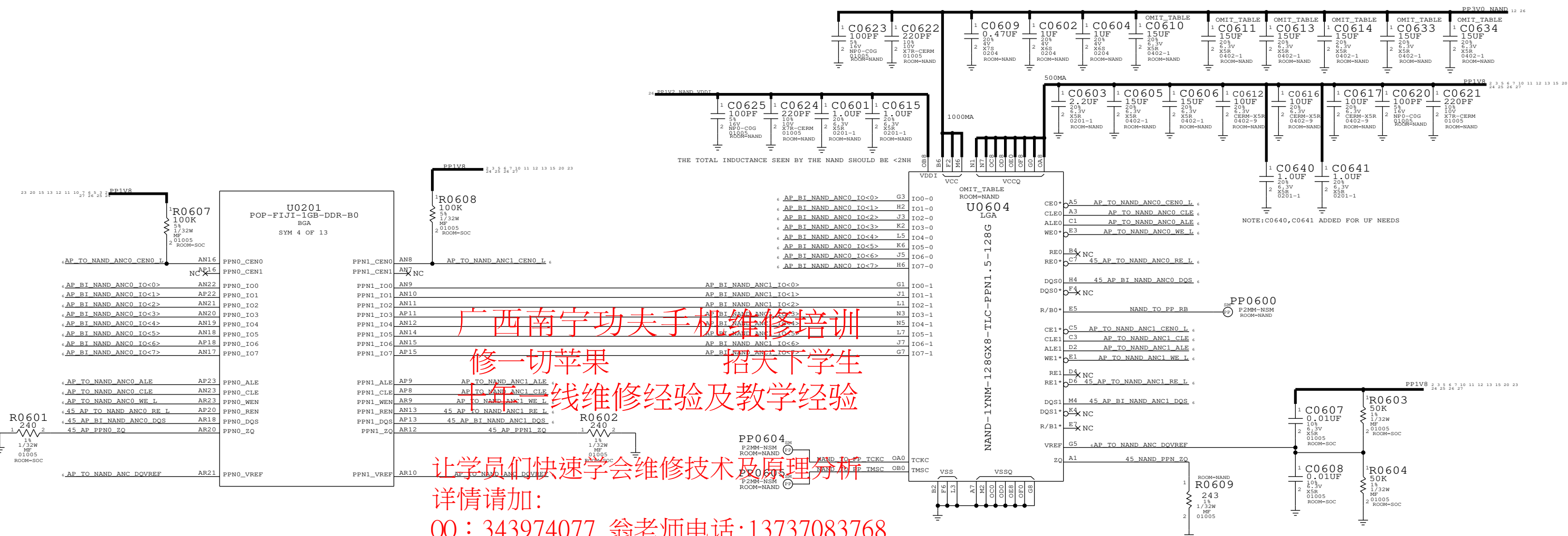

广西南宁功夫手机维修培训
 修一切苹果 招天下学生
 十年维修经验及教学经验
 让学员们快速学会维修技术及原理分析
 详情请加:
 QQ: 343974077 翁老师电话: 13737083768
 QQ: 344106191 王老师电话: 13737070888

PP0601 P4MM NOTE: IO<6> PREFERRED BY MATT BYOM (N51) (IS A STATUS READY BIT)
 ROOM-SOC 1 AP BI NAND ANCO IO<6>
 PP0602 P4MM
 ROOM-SOC 1 45 AP TO NAND ANCO RE L
 PP0603 P4MM
 ROOM-SOC 1 45 AP BI NAND ANCO DQS

SYNC MASTER=N56 MLB		SYNC DATE=08/29/2013	
SOC: NAND			
Apple Inc.		DRAWING NUMBER	SIZE
NOTICE OF PROPRIETARY PROPERTY: THE INFORMATION CONTAINED HEREIN IS THE PROPRIETARY PROPERTY OF APPLE INC. THE POSSESSOR AGREES TO THE FOLLOWING: I TO MAINTAIN THIS DOCUMENT IN CONFIDENCE II NOT TO REPRODUCE OR COPY IT III NOT TO REVEAL OR PUBLISH IT IN WHOLE OR PART IV ALL RIGHTS RESERVED		051-9903	D
		REVISION	
		BRANCH	
		PAGE	6 OF 55
		SHEET	6 OF 54

FIJI: HIGH SPEED DIG (CAM, LCD, LPDP, PCIE)

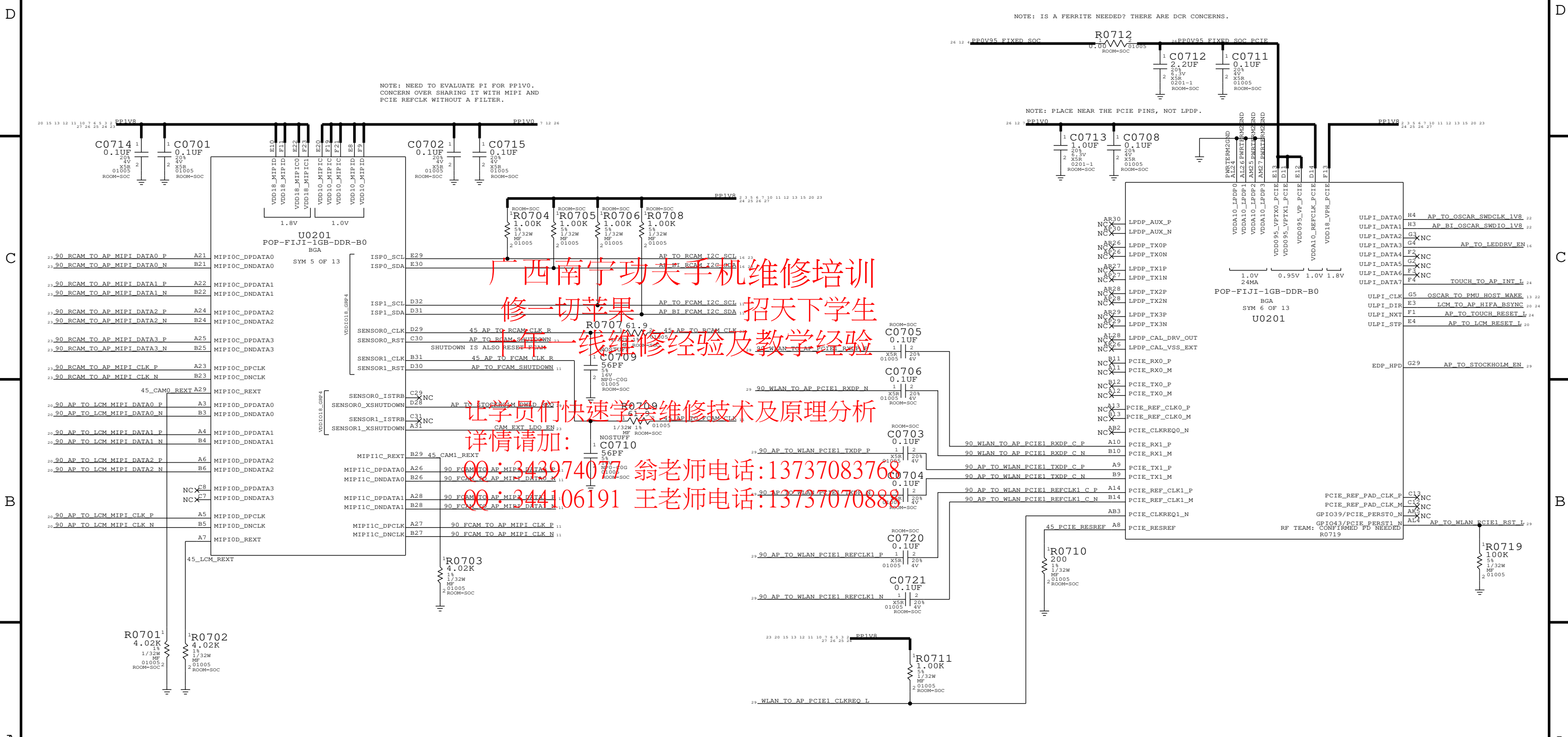

广西南宁功夫手机维修培训
 修一切苹果
 招天下学生
 让学员们快速学会维修技术及原理分析
 详情请加:
 QQ: 343974077 翁老师电话: 13737083768
 QQ: 344106191 王老师电话: 13737070888

SYNC MASTER=N56 MLB		SYNC DATE=08/29/2013	
PAGE TITLE			
SOC: CAM, LCD, LPDP, PCIE		DRAWING NUMBER	051-9903
Apple Inc.		REVISION	7.0.0
NOTICE OF PROPRIETARY PROPERTY:		BRANCH	
THE INFORMATION CONTAINED HEREIN IS THE PROPRIETARY PROPERTY OF APPLE INC. THE POSSESSOR AGREES TO THE FOLLOWING:		PAGE	7 OF 55
I TO MAINTAIN THIS DOCUMENT IN CONFIDENCE		SHEET	7 OF 54
II NOT TO REPRODUCE OR COPY IT			
III NOT TO REVEAL OR PUBLISH IT IN WHOLE OR PART			
IV ALL RIGHTS RESERVED			

BUTTON FLEX (BUTTONS, ANC REF MIC, STROBE, STROBE_NTC, WIFI FLEX PAC)

MIC2 (ANC REF MIC):
MIC2/4 BIAS,
MIC2_P,_N

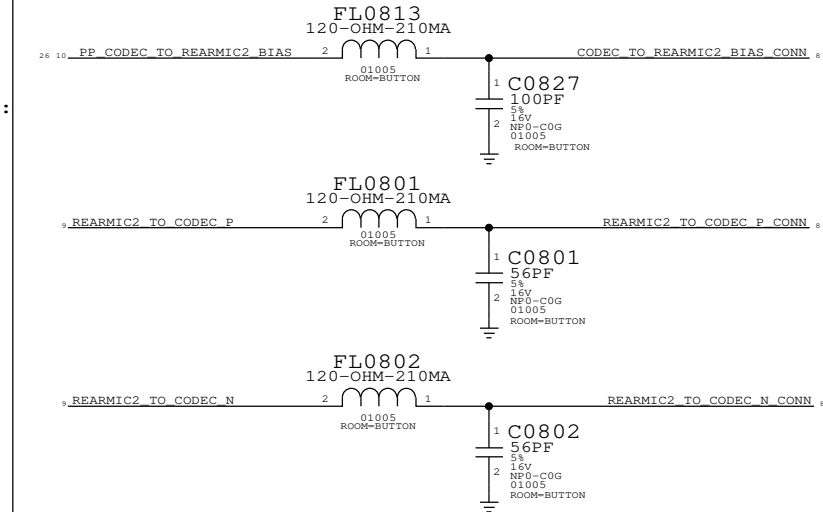

RIGHT BUTTON B2B

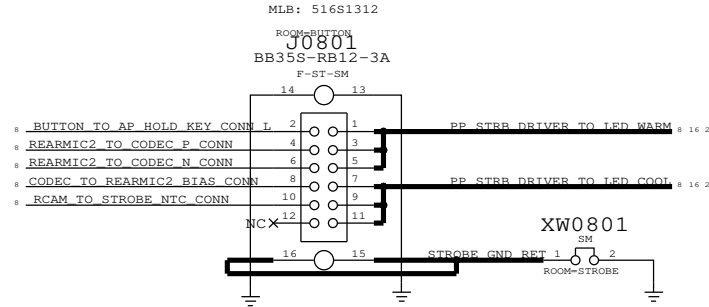

LEFT BUTTON B2B

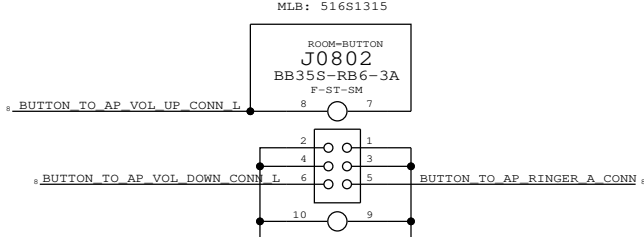

广西南宁功夫手机维修培训
修一切苹果 招天下学生
十年一线维修经验及教学经验

让学员们快速学会维修技术及原理分析
详情请加:
QQ: 343974077 翁老师电话: 13737083768
QQ: 344106191 王老师电话: 13737070888

BUTTONS:
RINGER, HOLD,
VOL_UP/DOWN,

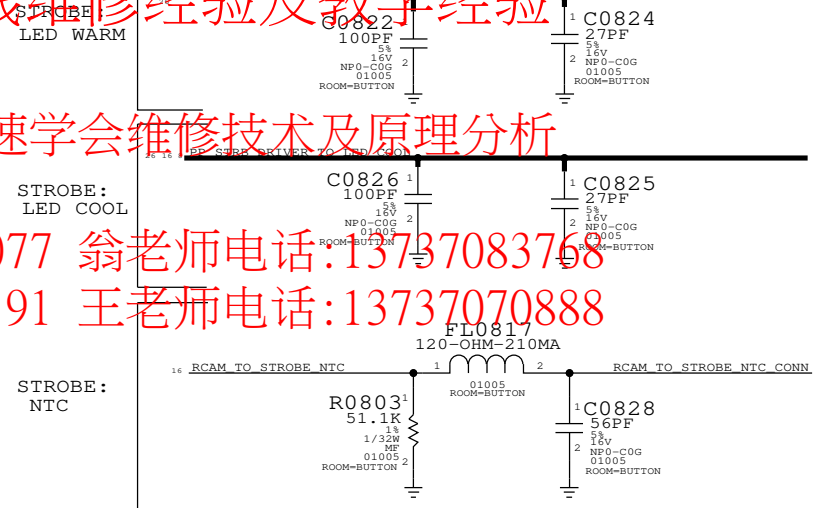
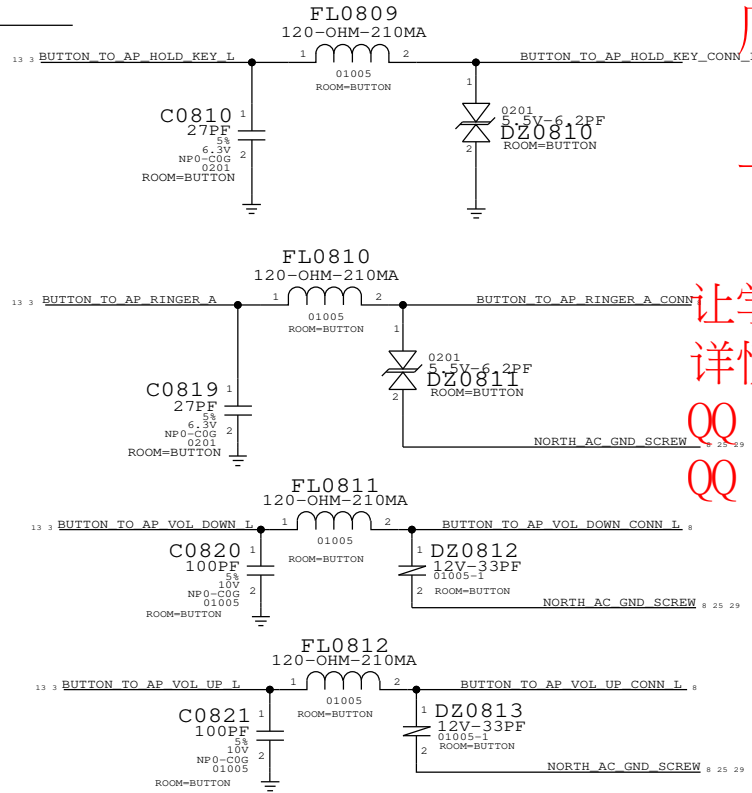

SYNC MASTER=N61_MLB		SYNC DATE=08/26/2013	
PAGE TITLE IO:BUTTON FLEX CONN			
Apple Inc.	DRAWING NUMBER	051-9903	SIZE D
	REVISION	7.0.0	
NOTICE OF PROPRIETARY PROPERTY:		BRANCH	
THE INFORMATION CONTAINED HEREIN IS THE PROPRIETARY PROPERTY OF APPLE INC. THE POSSESSOR AGREES TO THE FOLLOWING:		PAGE	
I TO MAINTAIN THIS DOCUMENT IN CONFIDENCE		8 OF 55	
II NOT TO REPRODUCE OR COPY IT		SHEET	
III NOT TO REVEAL OR PUBLISH IT IN WHOLE OR PART		8 OF 54	
IV ALL RIGHTS RESERVED			

L67 AUDIO CODEC

AUDIO I/O

(ANALOG MIC IN, DIG MIC IN, HPOUT, LINEOUT, RECEIVER OUT, MIKEYBUS)

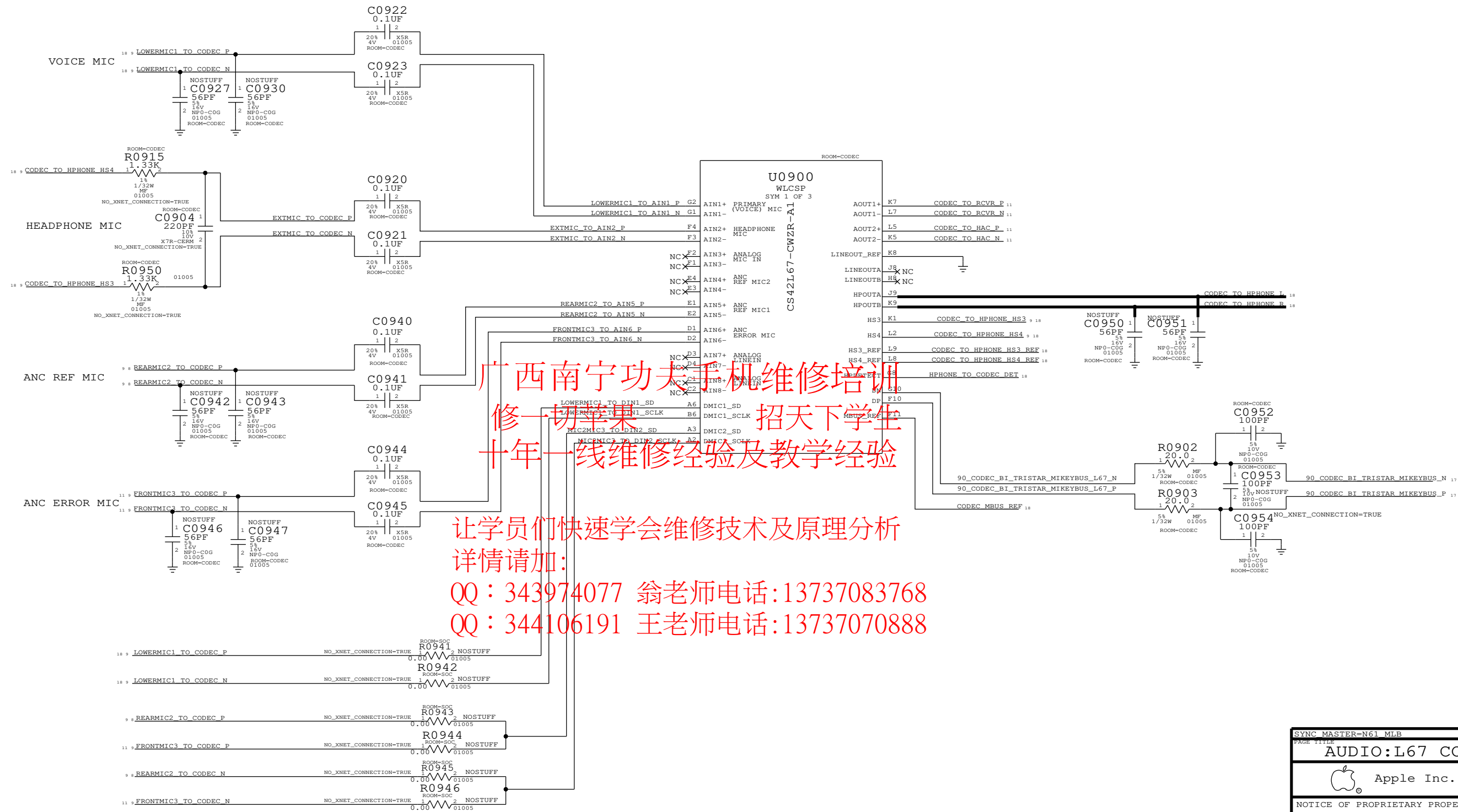

广西南宁功夫手机维修培训
 修一切苹果 招天下学生
 十年一线维修经验及教学经验

让学员们快速学会维修技术及原理分析
 详情请加:
 QQ: 343974077 翁老师电话:13737083768
 QQ: 344106191 王老师电话:13737070888

SYNC MASTER=N61 MLB		SYNC DATE=08/26/2013	
PAGE TITLE			
AUDIO:L67 CODEC (1/2)		DRAWING NUMBER	SIZE
Apple Inc.		051-9903	D
REVISION		7.0.0	
NOTICE OF PROPRIETARY PROPERTY:		BRANCH	
THE INFORMATION CONTAINED HEREIN IS THE PROPRIETARY PROPERTY OF APPLE, INC. THE POSSESSOR AGREES TO THE FOLLOWING:		PAGE	
I TO MAINTAIN THIS DOCUMENT IN CONFIDENCE		9 OF 55	
II NOT TO REPRODUCE OR COPY IT		SHEET	
III NOT TO REVEAL OR PUBLISH IT IN WHOLE OR PART		9 OF 54	
IV ALL RIGHTS RESERVED			

L67 AUDIO CODEC

POWER, MICBIAS

DIGITAL SYSTEM I/O

NOTE: C1022 WAS REDUCED TO 2.2UF BECAUSE OF ADDITIONAL NEARBY VCC MAIN CAPS

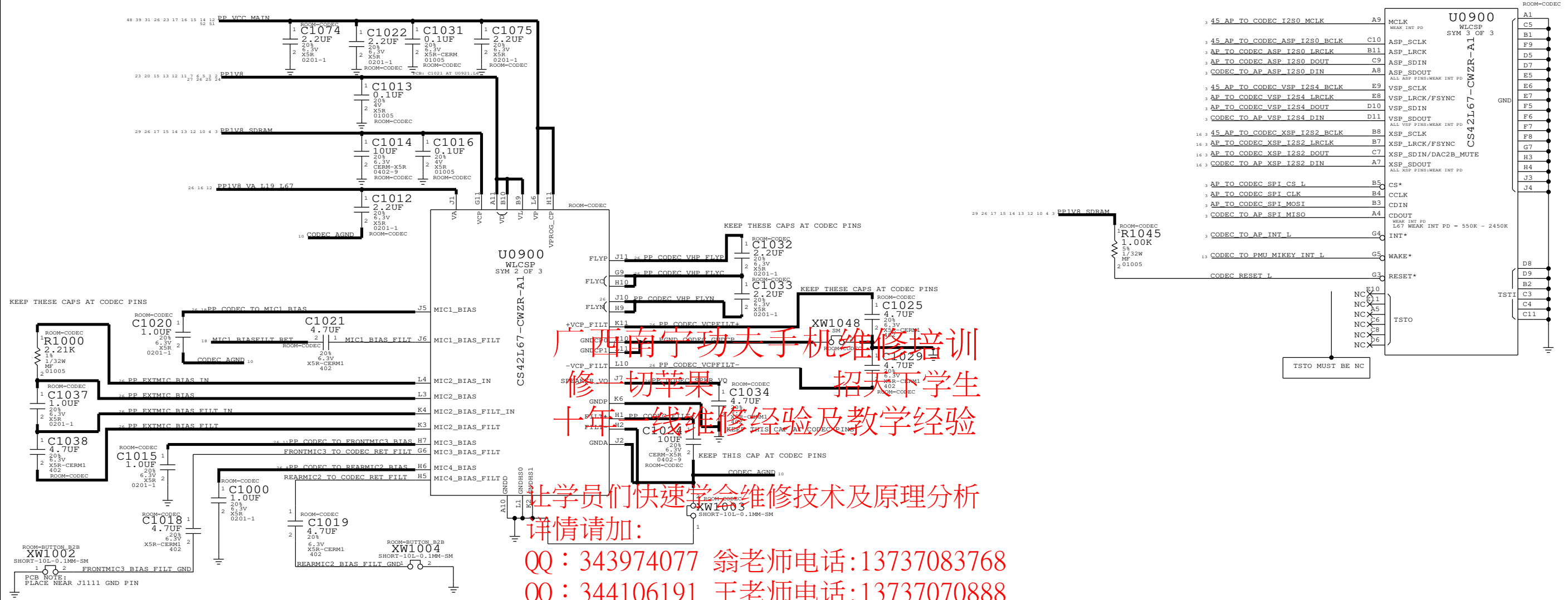

广西南宁功夫手机维修培训
 修一切苹果 招天下学生
 十年一线维修经验及教学经验
 让学员们快速学会维修技术及原理分析
 详情请加：
 QQ：343974077 翁老师电话：13737083768
 QQ：344106191 王老师电话：13737070888

SYNC MASTER=N61 MLB		SYNC DATE=08/26/2013	
PAGE TITLE			
AUDIO:L67 CODEC (2/2)		DRAWING NUMBER	SIZE
Apple Inc.		051-9903	D
		REVISION	
		7.0.0	
NOTICE OF PROPRIETARY PROPERTY:		BRANCH	
THE INFORMATION CONTAINED HEREIN IS THE PROPRIETARY PROPERTY OF APPLE, INC. THE POSSESSOR AGREES TO THE FOLLOWING:		PAGE	
I TO MAINTAIN THIS DOCUMENT IN CONFIDENCE		10 OF 55	
II NOT TO REPRODUCE OR COPY IT		SHEET	
III NOT TO REVEAL OR PUBLISH IT IN WHOLE OR PART		10 OF 54	
IV ALL RIGHTS RESERVED			

FRONT CAM FLEX B2B

(FCAM, PROX, ALS, RECEIVER, ANC ERROR MIC)

THIS ONE IS 516S1081 RECEPTACLE SENSOR FOOTBALL

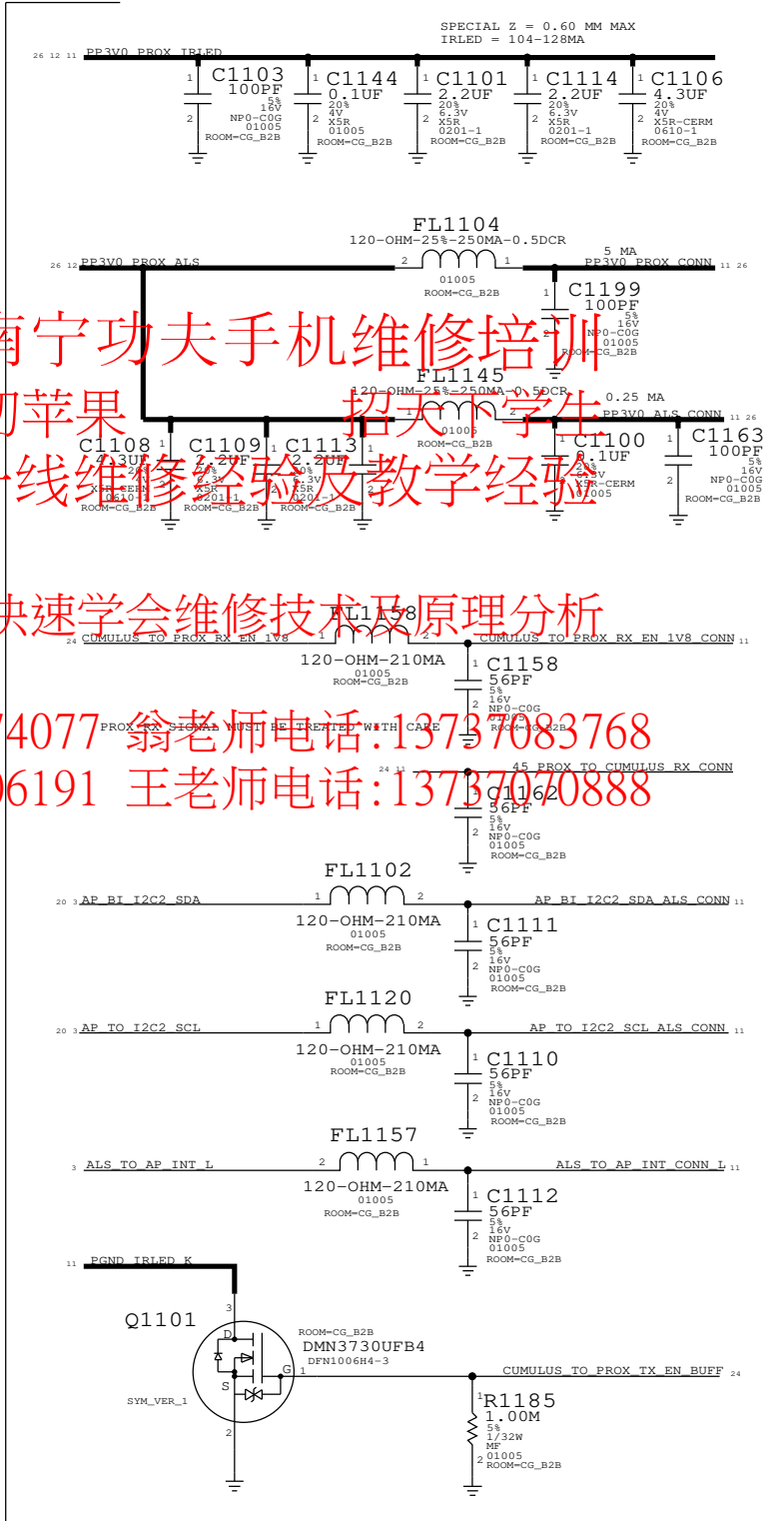
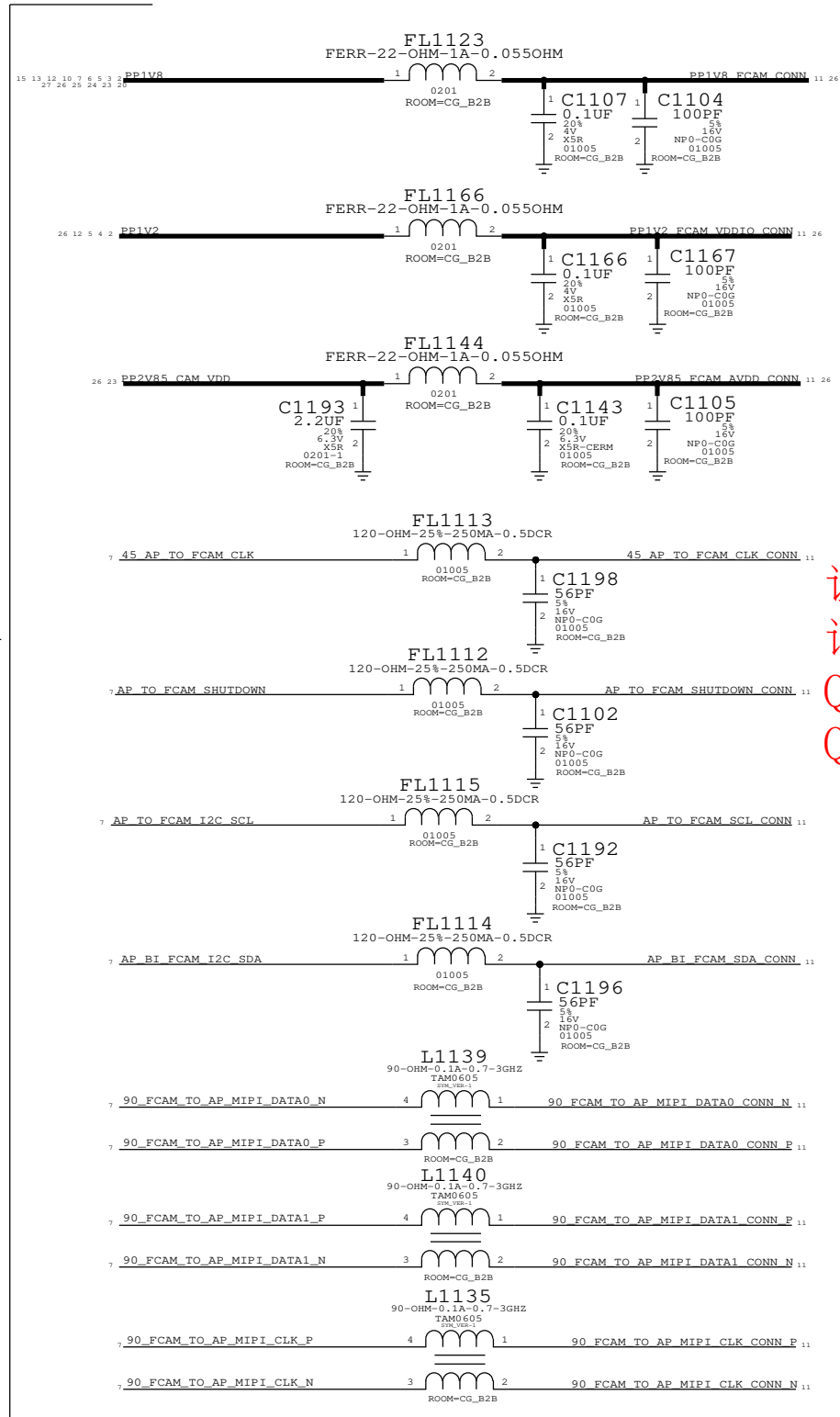
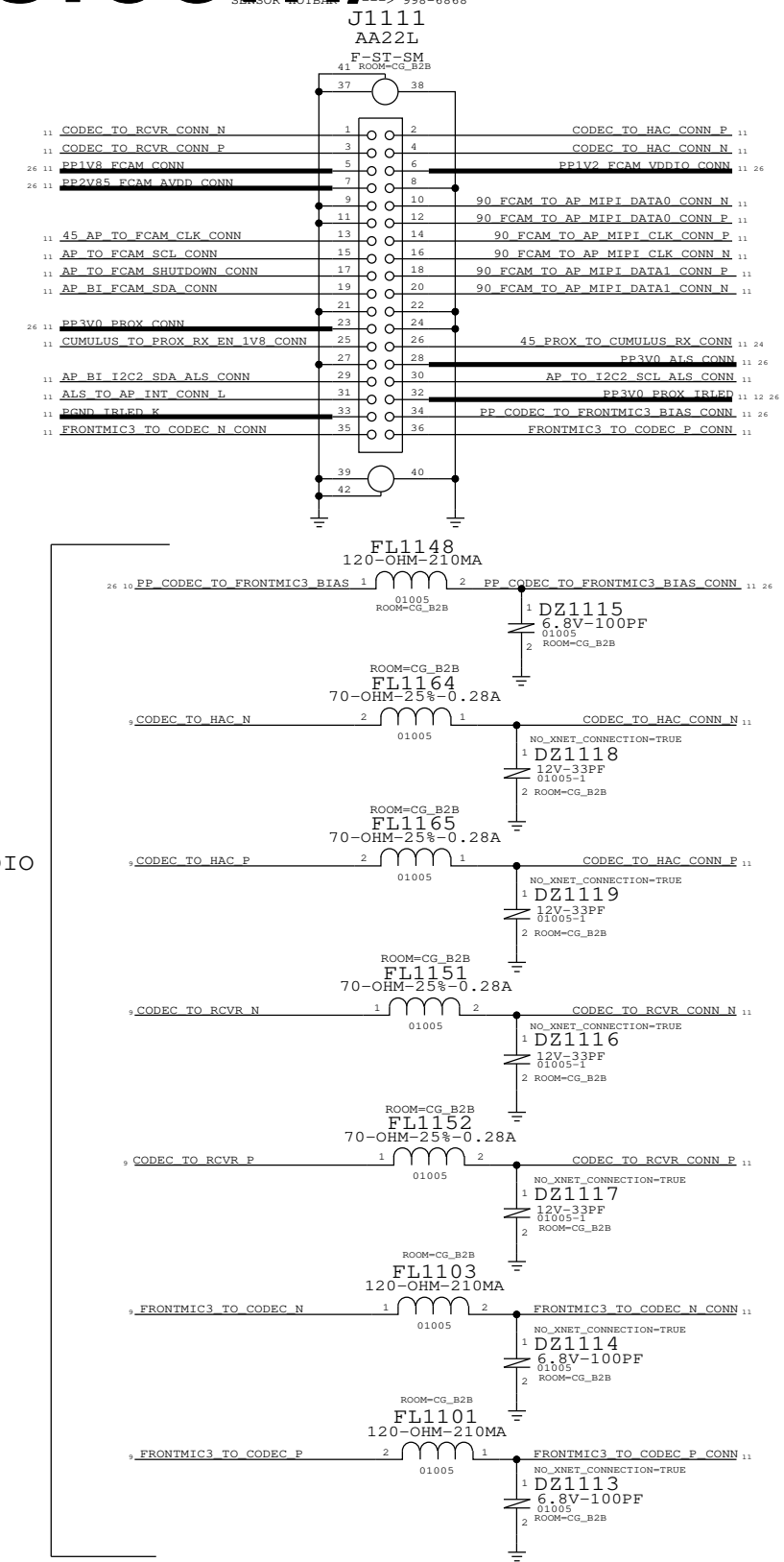

广西南宁功夫手机维修培训
修一切苹果
十年一线维修经验及教学经验
招天下学生

让学员们快速学会维修技术及原理分析
详情请加:
QQ: 343974077 翁老师电话: 13737083768
QQ: 344106191 王老师电话: 13737070888

PAGE TITLE		SYNC DATE=08/26/2013	
CAMERA: FRONT FLEX CONN			
Apple Inc.		DRAWING NUMBER	051-9903
		REVISION	7.0.0
NOTICE OF PROPRIETARY PROPERTY:			
THE INFORMATION CONTAINED HEREIN IS THE PROPRIETARY PROPERTY OF APPLE, INC. THE POSSESSOR AGREES TO THE FOLLOWING:			
I TO MAINTAIN THIS DOCUMENT IN CONFIDENCE		BRANCH	
II NOT TO REPRODUCE OR COPY IT		PAGE	11 OF 55
III NOT TO REVEAL OR PUBLISH IT IN WHOLE OR PART		SHEET	11 OF 54
IV ALL RIGHTS RESERVED			

ADI PMU (BUCK, LDO, VIBE DRIVER, 32K, CHARGER)

D
C
B
A

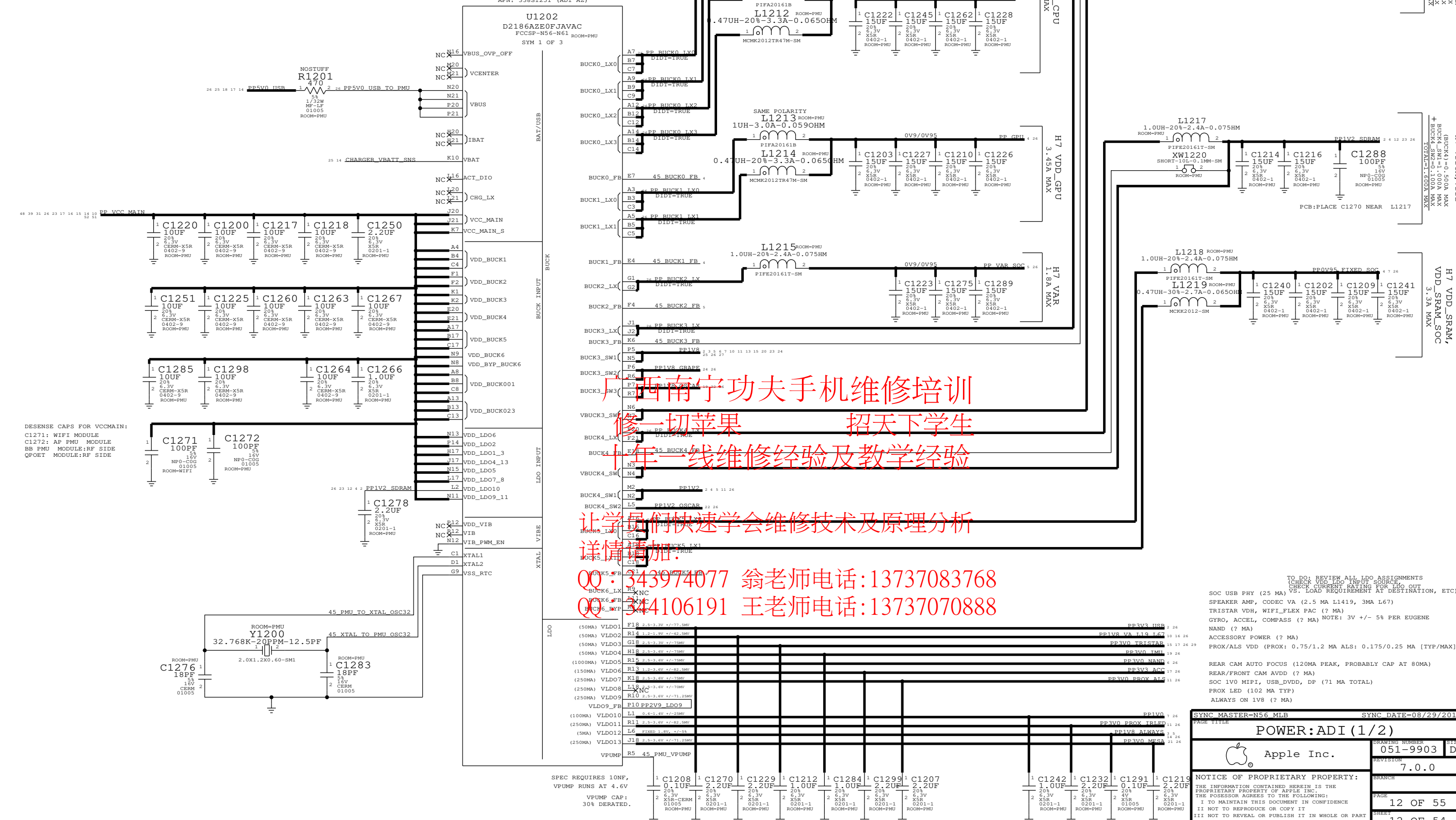

广西南宁功夫手机维修培训
 修一切苹果 招天下学生
 十年一线维修经验及教学经验
 让学员们快速学会维修技术及原理分析
 详情请加:

QQ: 343974077 翁老师电话: 13737083768
 QQ: 344106191 王老师电话: 13737070888

TO DO: REVIEW ALL LDO ASSIGNMENTS (CHECK VDD LDO INPUT SOURCE, CHECK CURRENT RATING FOR LDO OUT VS. LOAD REQUIREMENT AT DESTINATION, ETC)

PP3V3 USB	26
PP1V8 VA I19 I67	10 14 26
PP3V0 TRISTAR	15 17 24 29
PP3V0 PMU	19 26
PP1V0 NANI	4 26
PP3V3 AGC	17 26
PP3V0 PROX ALS	11 26

REAR CAM AUTO FOCUS (120MA PEAK, PROBABLY CAP AT 80MA)
 REAR/FRONT CAM AVDD (? MA)
 SOC IVO MIPI, USB_DVDD, DP (71 MA TOTAL)
 PROX LED (102 MA TYP)
 ALWAYS ON I1V8 (? MA)

SYNC MASTER=N56 MLB SYNC DATE=08/29/2013

POWER:ADI (1/2)

Apple Inc.

NOTICE OF PROPRIETARY PROPERTY:
 THE INFORMATION CONTAINED HEREIN IS THE PROPRIETARY PROPERTY OF APPLE INC. THE POSSESSOR AGREES TO THE FOLLOWING:
 I TO MAINTAIN THIS DOCUMENT IN CONFIDENCE
 II NOT TO REPRODUCE OR COPY IT
 III NOT TO REVEAL OR PUBLISH IT IN WHOLE OR PART
 IV ALL RIGHTS RESERVED

DRAWING NUMBER	051-9903	SIZE	D
REVISION	7.0.0	BRANCH	
PAGE	12 OF 55	SHEET	12 OF 54

ADI PMU

(AMUX, GPIO, BUTTONS, ADC, THERMISTORS, SYSTEM I/F, GND)

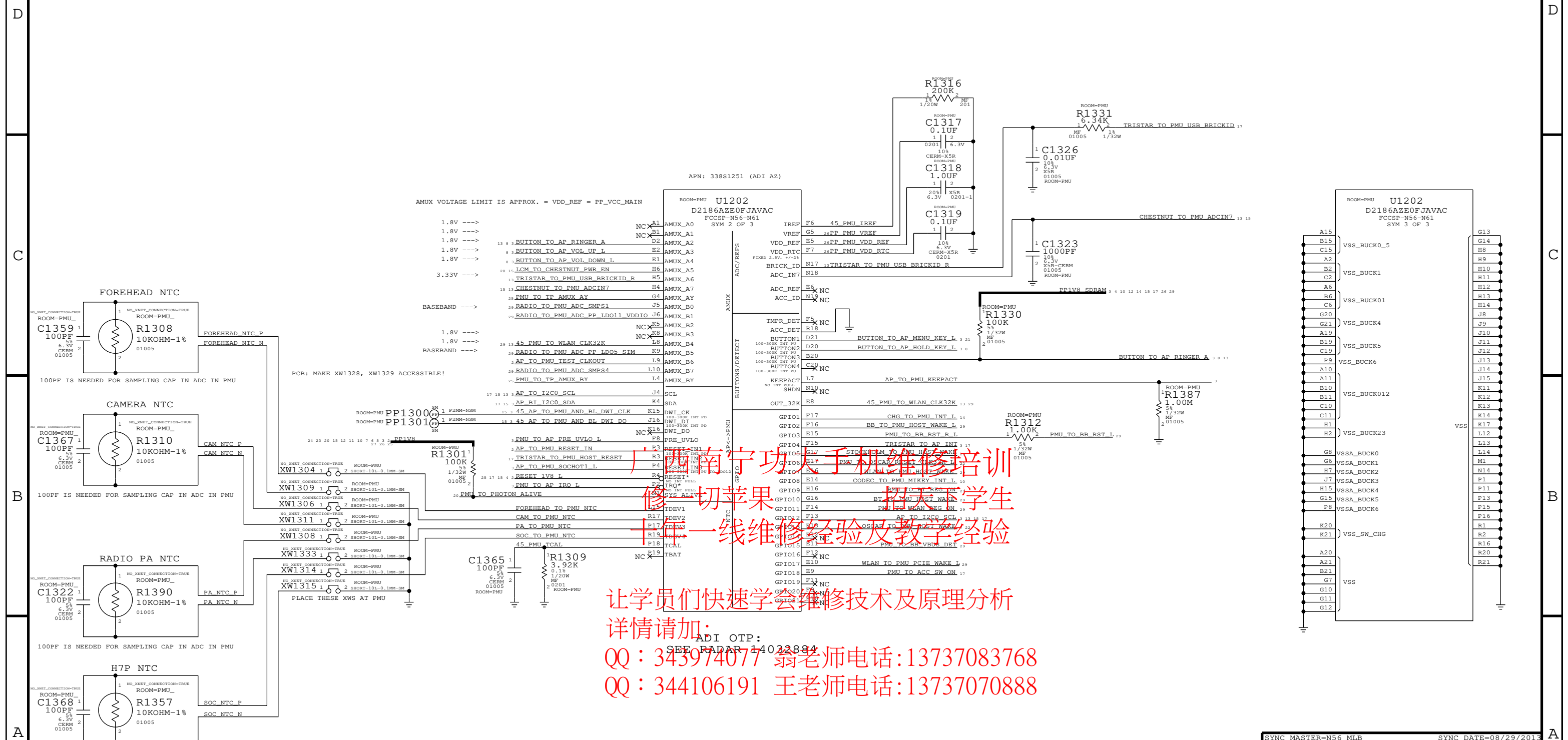

广东南宁苹果手机维修培训
 招生对象：学生
 十年一线维修经验及教学经验

让学员们快速学会维修技术及原理分析
 详情请加：
 QQ: 343974077 翁老师电话: 13737083768
 QQ: 344106191 王老师电话: 13737070888

SYNC MASTER=N56 MLB		SYNC DATE=08/29/2013	
PAGE TITLE POWER:ADI (2/2)			
Apple Inc.	DRAWING NUMBER	051-9903	SIZE D
	REVISION	7.0.0	
NOTICE OF PROPRIETARY PROPERTY:		BRANCH	
THE INFORMATION CONTAINED HEREIN IS THE PROPRIETARY PROPERTY OF APPLE INC. THE POSSESSOR AGREES TO THE FOLLOWING:		PAGE	13 OF 55
I TO MAINTAIN THIS DOCUMENT IN CONFIDENCE		SHEET	13 OF 54
II NOT TO REPRODUCE OR COPY IT			
III NOT TO REVEAL OR PUBLISH IT IN WHOLE OR PART			
IV ALL RIGHTS RESERVED			

TIGRIS CHARGER & VIBE DRIVER

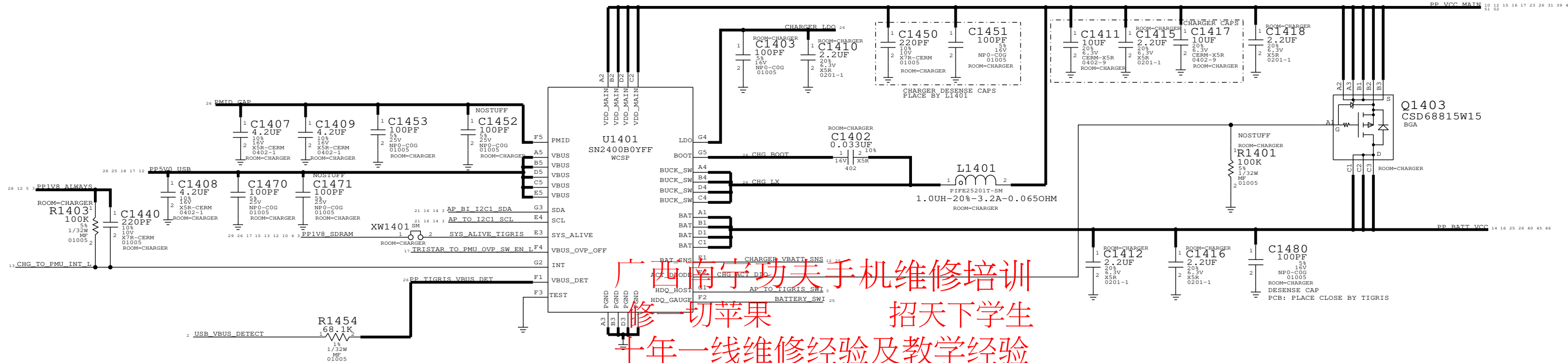

广西南宁宁功夫手机维修培训
 修一切苹果 招天下学生
 十年一线维修经验及教学经验

让学员们快速学会维修技术及原理分析
 详情请加：
 QQ：343974077 翁老师电话：13737083768
 QQ：344106191 吕老师电话：13737070888

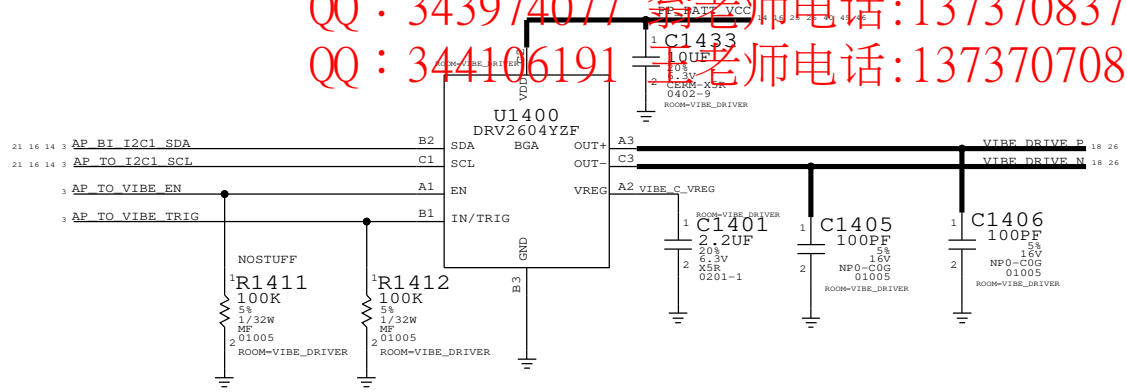

POWER: TIGRIS, VIBE DRIVER		
Apple Inc.	DRAWING NUMBER	051-9903
	REVISION	7.0.0
NOTICE OF PROPRIETARY PROPERTY:		
THE INFORMATION CONTAINED HEREIN IS THE PROPRIETARY PROPERTY OF APPLE, INC. THE POSSESSOR AGREES TO THE FOLLOWING:		
I TO MAINTAIN THIS DOCUMENT IN CONFIDENCE	PAGE	14 OF 55
II NOT TO REPRODUCE OR COPY IT	SHEET	14 OF 54
III NOT TO REVEAL OR PUBLISH IT IN WHOLE OR PART		
IV ALL RIGHTS RESERVED		

CHESTNUT, BACKLIGHT DRIVER, MESA BOOST

D500 DISPLAY PMU (TI CHESTNUT, 338S1149)

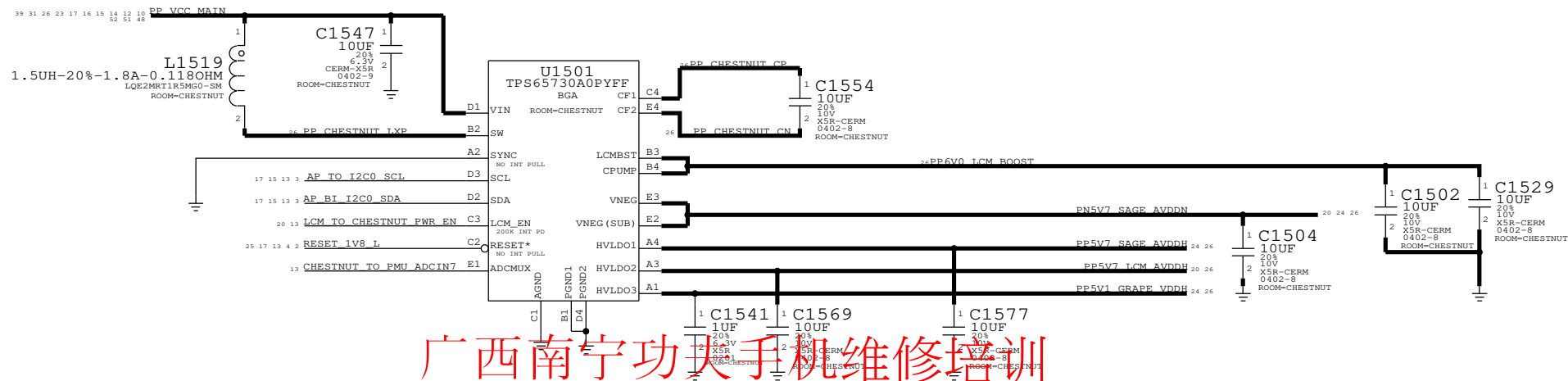

广西南宁功夫手机维修培训
修一切苹果 招天下学生
十年一线维修经验及教学经验

D500 BACKLIGHT DRIVER

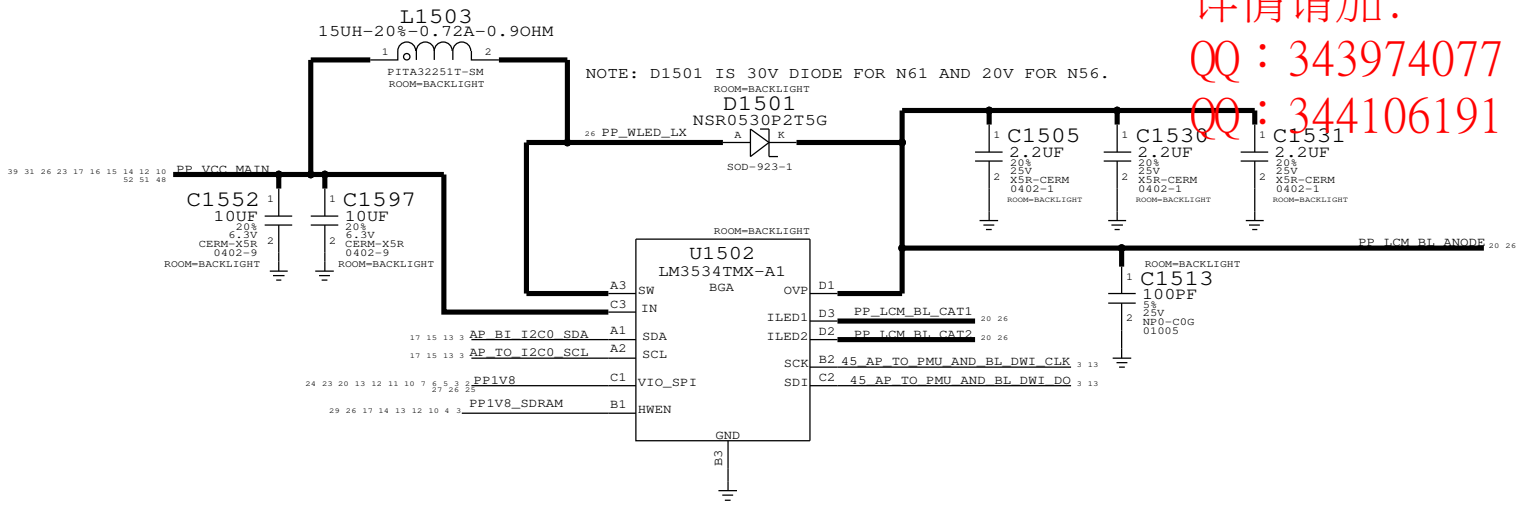

让学员们快速学会维修技术及原理分析
详情请加:
QQ: 343974077 翁老师电话: 13737083768
QQ: 344106191 王老师电话: 13737070888

MESA BOOST A0

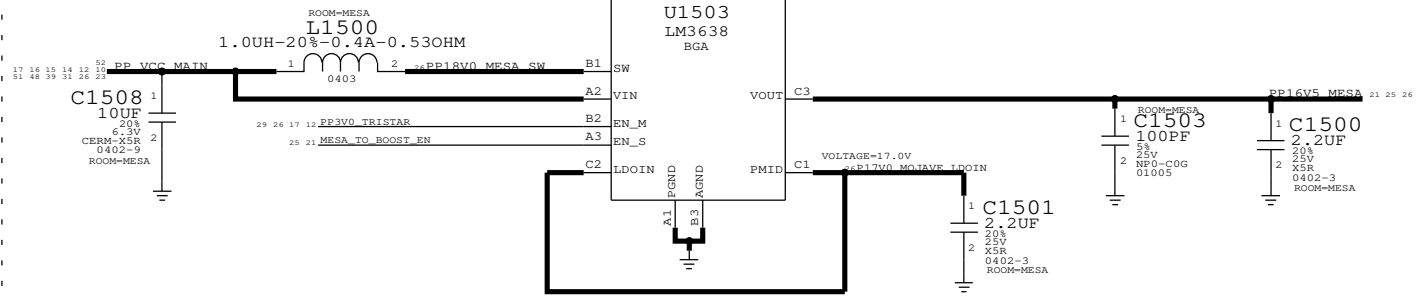

SYNC MASTER=N61 MLB		SYNC DATE=08/26/2013	
PAGE TITLE DISPLAY: CHESTNUT, BACKLIGHT DRIVER			
DRAWING NUMBER 051-9903		SIZE D	
REVISION 7.0.0		BRANCH	
NOTICE OF PROPRIETARY PROPERTY: THE INFORMATION CONTAINED HEREIN IS THE PROPRIETARY PROPERTY OF APPLE, INC. THE POSSESSOR AGREES TO THE FOLLOWING: I TO MAINTAIN THIS DOCUMENT IN CONFIDENCE II NOT TO REPRODUCE OR COPY IT III NOT TO REVEAL OR PUBLISH IT IN WHOLE OR PART IV ALL RIGHTS RESERVED			
PAGE 15 OF 55		SHEET 15 OF 54	

SPEAKER AMP, LED DRIVER

SPEAKER AMP

I2C ADDRESS: 1000000X

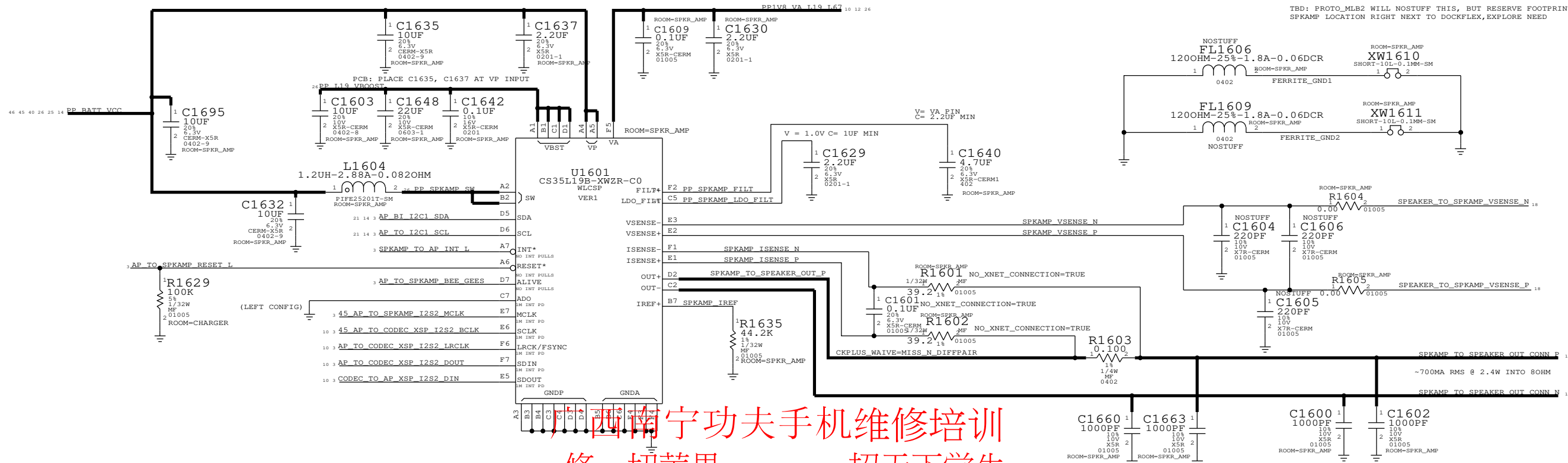

广西南宁功夫手机维修培训
 修一切苹果 招天下学生
 十年一线维修经验及教学经验
 STROBE DRIVER

让学员们快速学会维修技术及原理分析
 详情请加:
 QQ: 343974077 翁老师电话: 13737083768
 QQ: 344106191 王老师电话: 13737070888

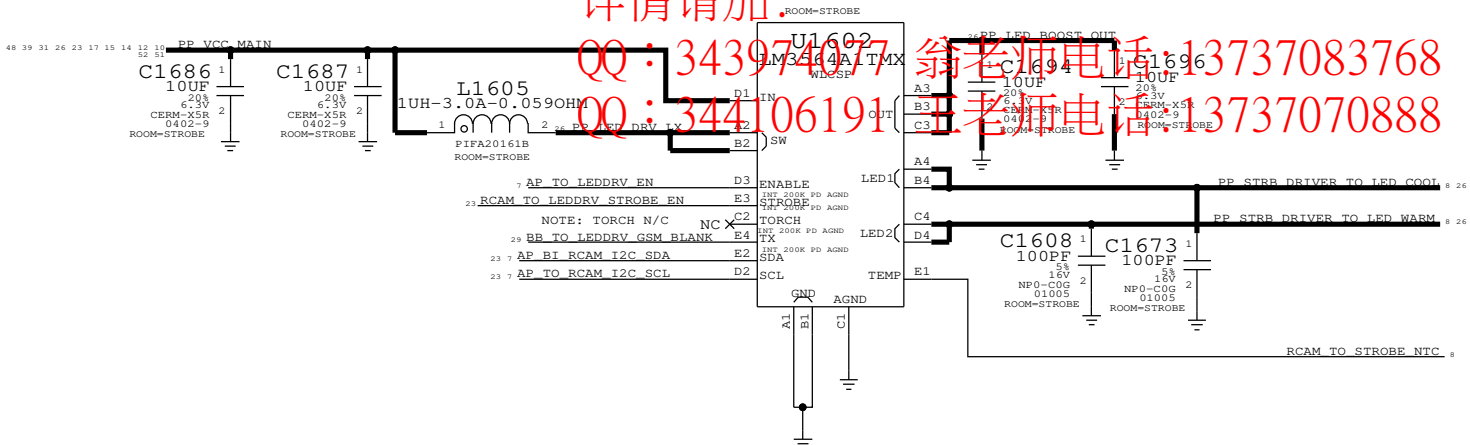

SYNC MASTER=N61_MLB		SYNC DATE=08/26/2013	
PAGE TITLE			
AUDIO: SPKR AMP, STROBE			
Apple Inc.		DRAWING NUMBER	051-9903
		REVISION	7.0.0
NOTICE OF PROPRIETARY PROPERTY:		BRANCH	
THE INFORMATION CONTAINED HEREIN IS THE PROPRIETARY PROPERTY OF APPLE, INC. THE POSSESSOR AGREES TO THE FOLLOWING:		PAGE	16 OF 55
I TO MAINTAIN THIS DOCUMENT IN CONFIDENCE		SHEET	16 OF 54
II NOT TO REPRODUCE OR COPY IT			
III NOT TO REVEAL OR PUBLISH IT IN WHOLE OR PART			
IV ALL RIGHTS RESERVED			

TRISTAR2

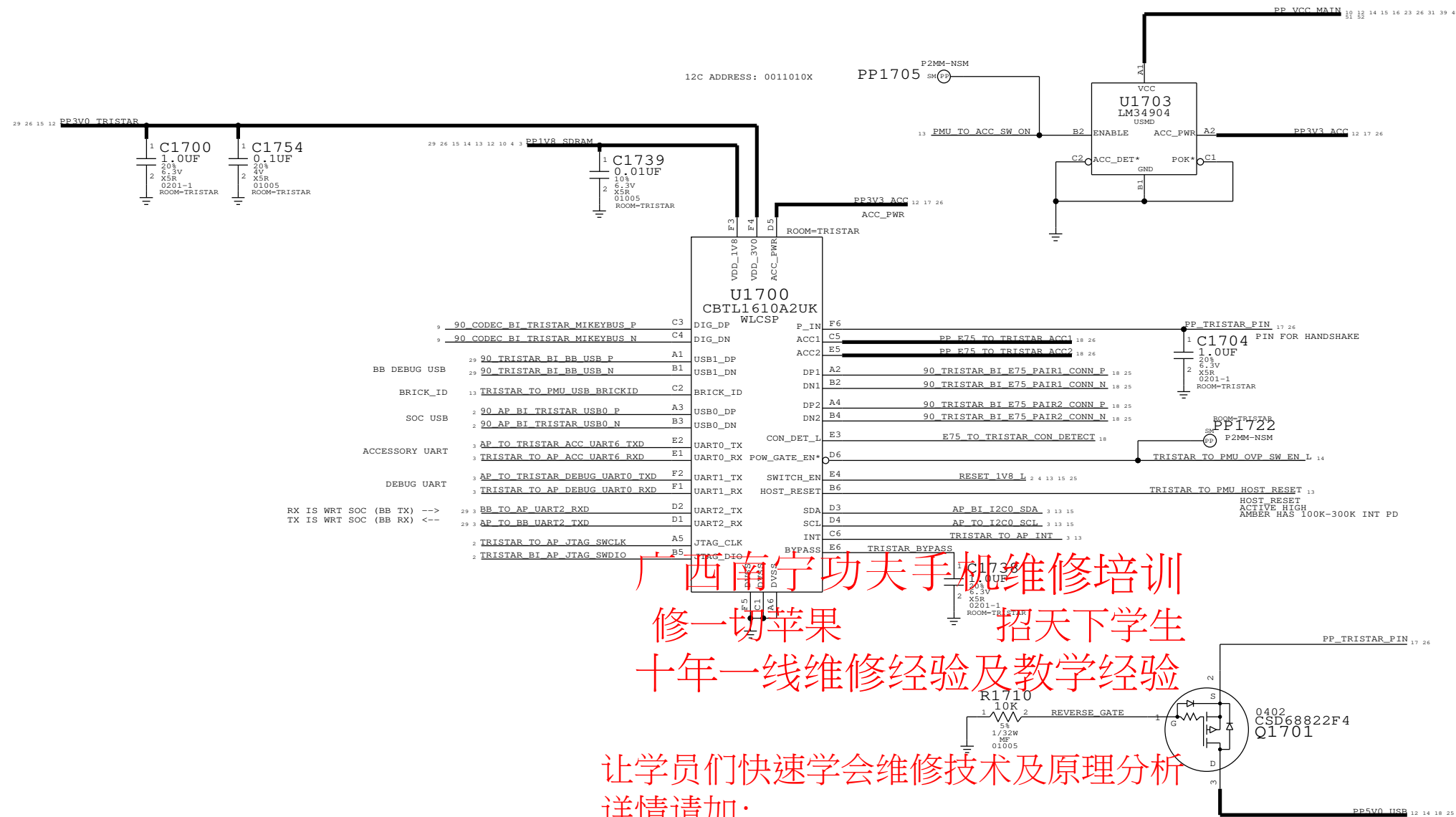

广西南宁功夫手机维修培训
 修一切苹果 招天下学生
 十年一线维修经验及教学经验

让学员们快速学会维修技术及原理分析
 详情请加：
 QQ：343974077 翁老师电话：13737083768
 QQ：344106191 王老师电话：13737070888

SYNC MASTER=N61 MLB		SYNC DATE=08/26/2013	
IO:TRISTAR2			
DRAWING NUMBER		SIZE	
051-9903		D	
REVISION		BRANCH	
7.0.0			
NOTICE OF PROPRIETARY PROPERTY:			
THE INFORMATION CONTAINED HEREIN IS THE PROPRIETARY PROPERTY OF APPLE, INC. THE POSSESSOR AGREES TO THE FOLLOWING:			
I TO MAINTAIN THIS DOCUMENT IN CONFIDENCE			
II NOT TO REPRODUCE OR COPY IT			
III NOT TO REVEAL OR PUBLISH IT IN WHOLE OR PART			
IV ALL RIGHTS RESERVED			
PAGE		PAGE	
17 OF 55		17 OF 54	

DOCKFLEX B2B (USB, VBUS, SPEAKER, ANTENNA, LAP SW CTRL, MIC1 (PRIMARY MIC), ACC DET/ID/PWR, E75 DIFFPAIRS)

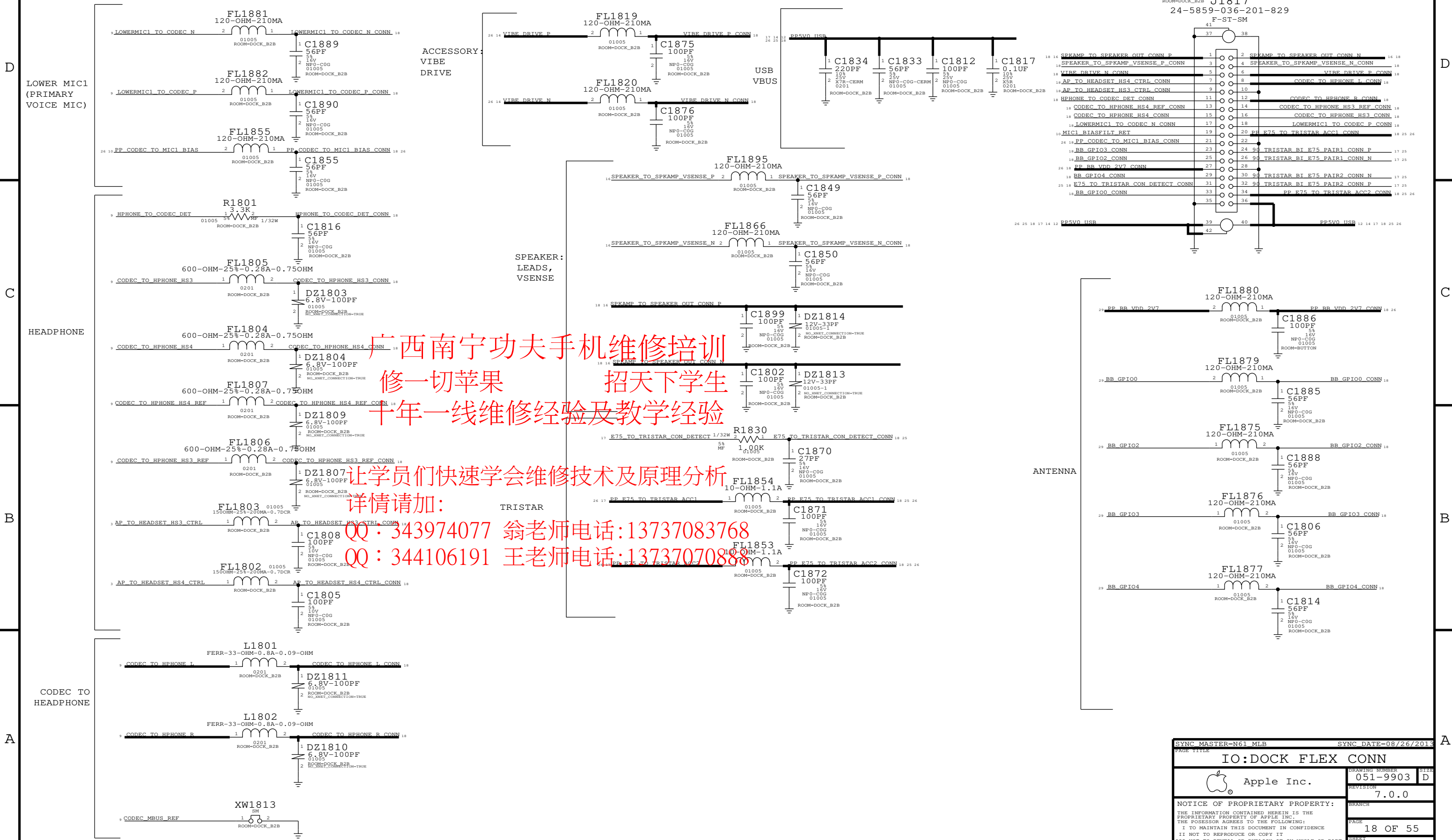

广西南宁功夫手机维修培训
修一切苹果
招天下学生
十年一线维修经验及教学经验

让学员们快速学会维修技术及原理分析
详情请加:
QQ: 343974077 翁老师电话: 13737083768
QQ: 344106191 王老师电话: 13737070888

SYNC MASTER=N61 MLB		SYNC DATE=08/26/2013	
PAGE TITLE IO:DOCK FLEX CONN			
Apple Inc.	DRAWING NUMBER	051-9903	SIZE D
	REVISION	7.0.0	
NOTICE OF PROPRIETARY PROPERTY:		BRANCH	PAGE
THE INFORMATION CONTAINED HEREIN IS THE PROPRIETARY PROPERTY OF APPLE, INC. THE POSSESSOR AGREES TO THE FOLLOWING:		I TO MAINTAIN THIS DOCUMENT IN CONFIDENCE	18 OF 55
II NOT TO REPRODUCE OR COPY IT		SHEET	18 OF 54
III NOT TO REVEAL OR PUBLISH IT IN WHOLE OR PART		IV ALL RIGHTS RESERVED	

COMPASS CSP: 338S1014

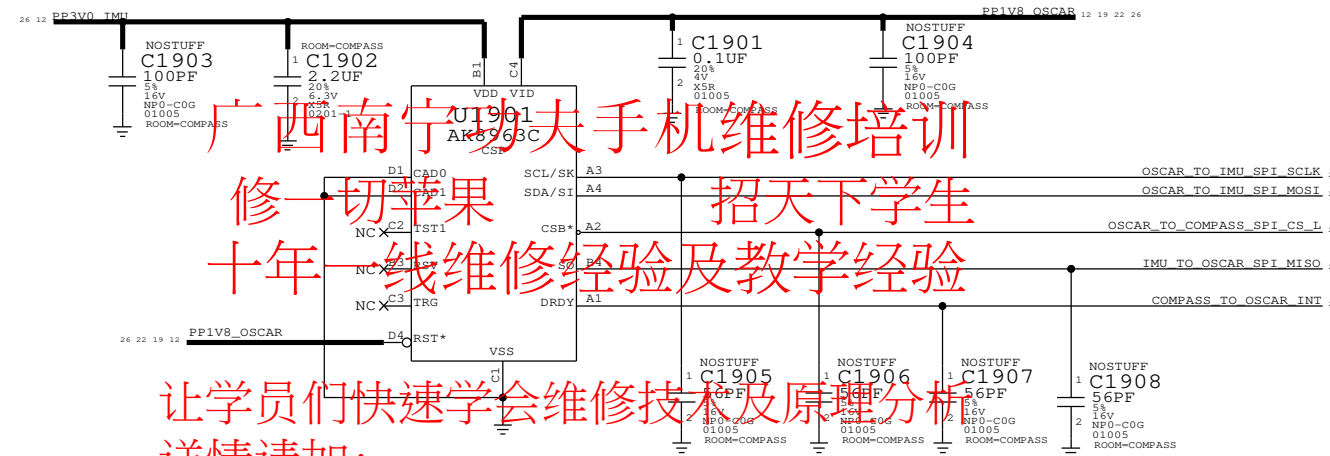

广西南宁翁老师手机维修培训
 修一切苹果 招天下学生
 十年一线维修经验及教学经验

让学员们快速学会维修技术及原理分析
 详情请加：
 QQ：343974077 翁老师电话：13737083768
 QQ：344106191 王老师电话：13737070888

SYNC MASTER=N61 MLB		SYNC DATE=08/26/2013	
SENSORS: COMPASS			
Apple Inc.		DRAWING NUMBER	SIZE
		051-9903	D
		REVISION	
		7.0.0	
NOTICE OF PROPRIETARY PROPERTY: THE INFORMATION CONTAINED HEREIN IS THE PROPRIETARY PROPERTY OF APPLE, INC. THE POSSESSOR AGREES TO THE FOLLOWING: I TO MAINTAIN THIS DOCUMENT IN CONFIDENCE II NOT TO REPRODUCE OR COPY IT III NOT TO REVEAL OR PUBLISH IT IN WHOLE OR PART IV ALL RIGHTS RESERVED		BRANCH	
		PAGE	19 OF 55
		SHEET	19 OF 54

LCD B2B

Backlight
(N56 HAS A 2ND SET OF BL SIGNALS ON P. 19).

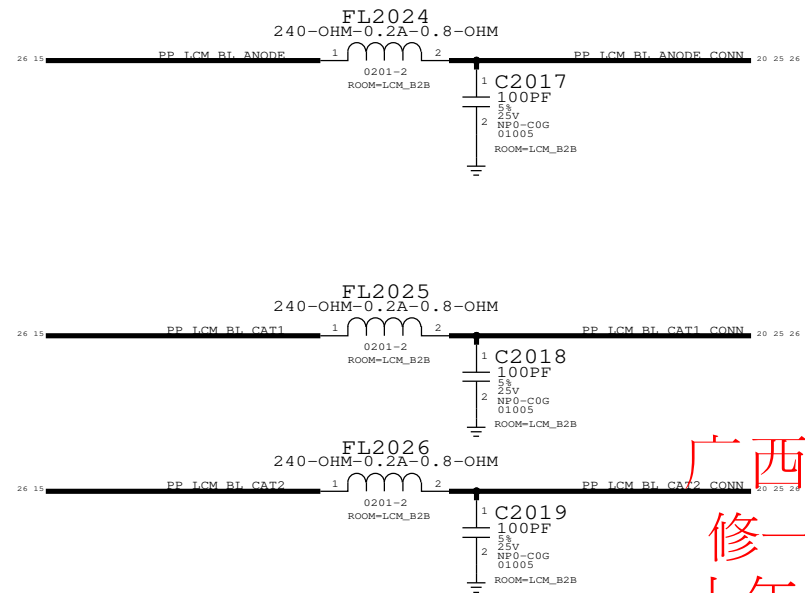

LCM Supplies

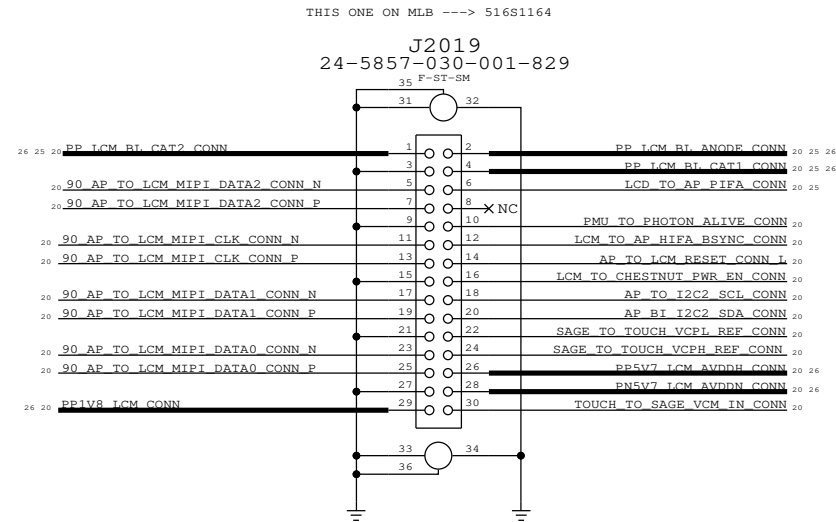
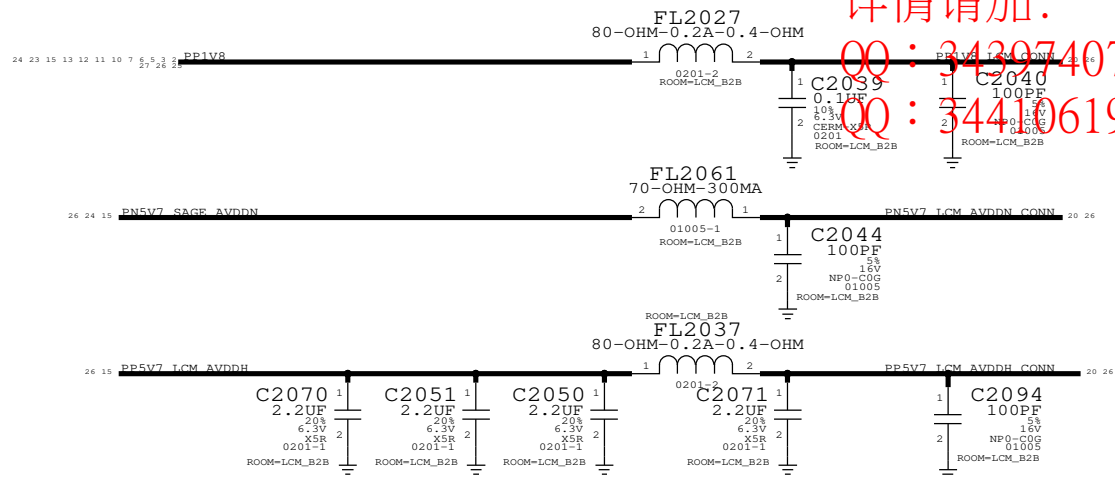

MIPI Common Mode Chokes
(N56 HAS A 4TH MIPI LANE ON P. 19).

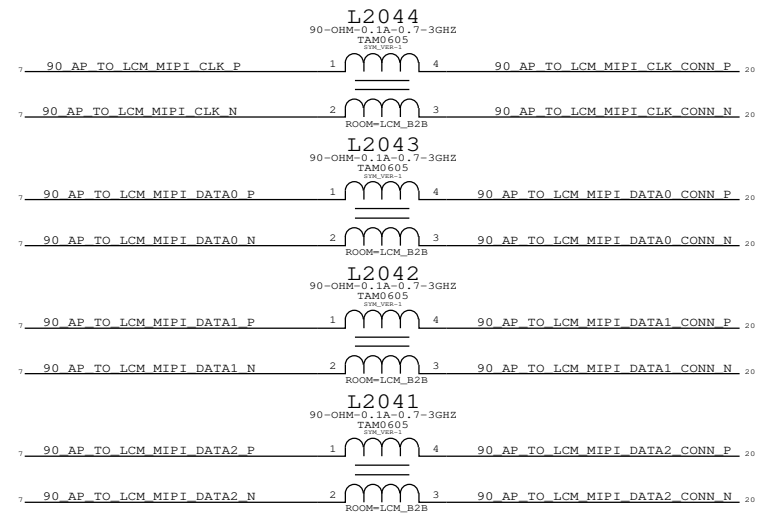

Sync/Reset/Debug

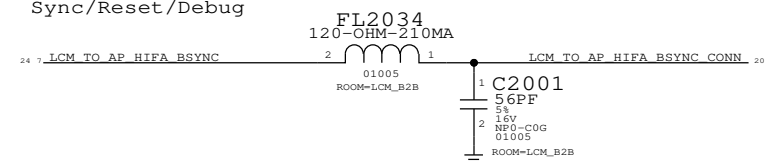

Touch

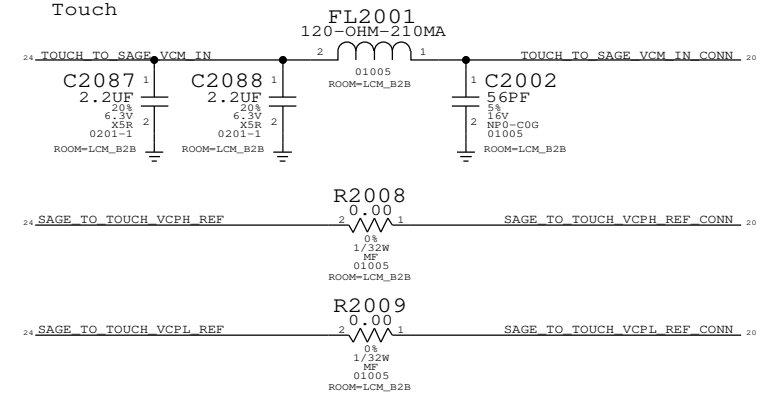

广西南宁功夫手机维修培训
 修一切苹果 招天下学生
 十年一线维修经验及教学经验

让学员们快速学会维修技术及原理分析
 详情请加:

QQ: 343974077 翁老师电话: 13737083768
 QQ: 344106191 王老师电话: 13737070888

SYNC MASTER=N61 MLB		SYNC DATE=08/26/2013	
PAGE TITLE			
DISPLAY:FLEX CONN			
Apple Inc.		DRAWING NUMBER	051-9903
		REVISION	7.0.0
NOTICE OF PROPRIETARY PROPERTY:		BRANCH	
THE INFORMATION CONTAINED HEREIN IS THE PROPRIETARY PROPERTY OF APPLE, INC. THE POSSESSOR AGREES TO THE FOLLOWING:		PAGE	20 OF 55
I TO MAINTAIN THIS DOCUMENT IN CONFIDENCE		SHEET	20 OF 54
II NOT TO REPRODUCE OR COPY IT			
III NOT TO REVEAL OR PUBLISH IT IN WHOLE OR PART			
IV ALL RIGHTS RESERVED			

MESA CONNECTOR

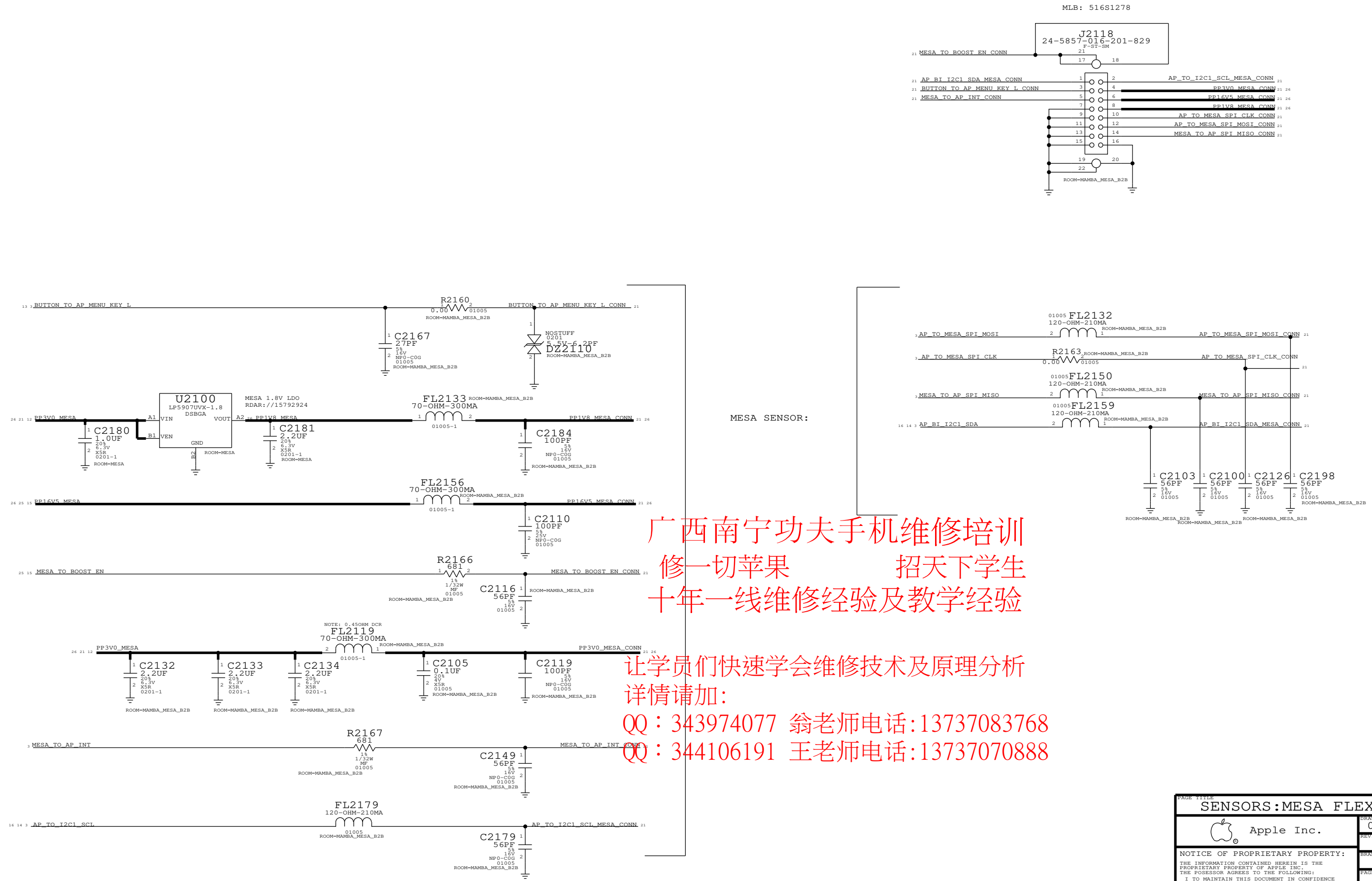

MESA SENSOR:

广西南宁功夫手机维修培训
修一切苹果 招天下学生
十年一线维修经验及教学经验

让学员们快速学会维修技术及原理分析
详情请加:
QQ: 343974077 翁老师电话: 13737083768
QQ: 344106191 王老师电话: 13737070888

PAGE TITLE		
SENSORS:MESA FLEX CONN		
Apple Inc.	DRAWING NUMBER	051-9903
	REVISION	7.0.0
NOTICE OF PROPRIETARY PROPERTY:		
THE INFORMATION CONTAINED HEREIN IS THE PROPRIETARY PROPERTY OF APPLE, INC. THE POSSESSOR AGREES TO THE FOLLOWING:		
I TO MAINTAIN THIS DOCUMENT IN CONFIDENCE	BRANCH	
II NOT TO REPRODUCE OR COPY IT	PAGE	21 OF 55
III NOT TO REVEAL OR PUBLISH IT IN WHOLE OR PART	SHEET	21 OF 54
IV ALL RIGHTS RESERVED		

OSCAR + SENSORS

OSCAR VDDIO = 1.8V ALWAYS ON (NEED TO MAKE HOST & RUN PLL)
OSCAR CORE = 1.2V ALWAYS ON (NEED TO RUN IN SDRAM)

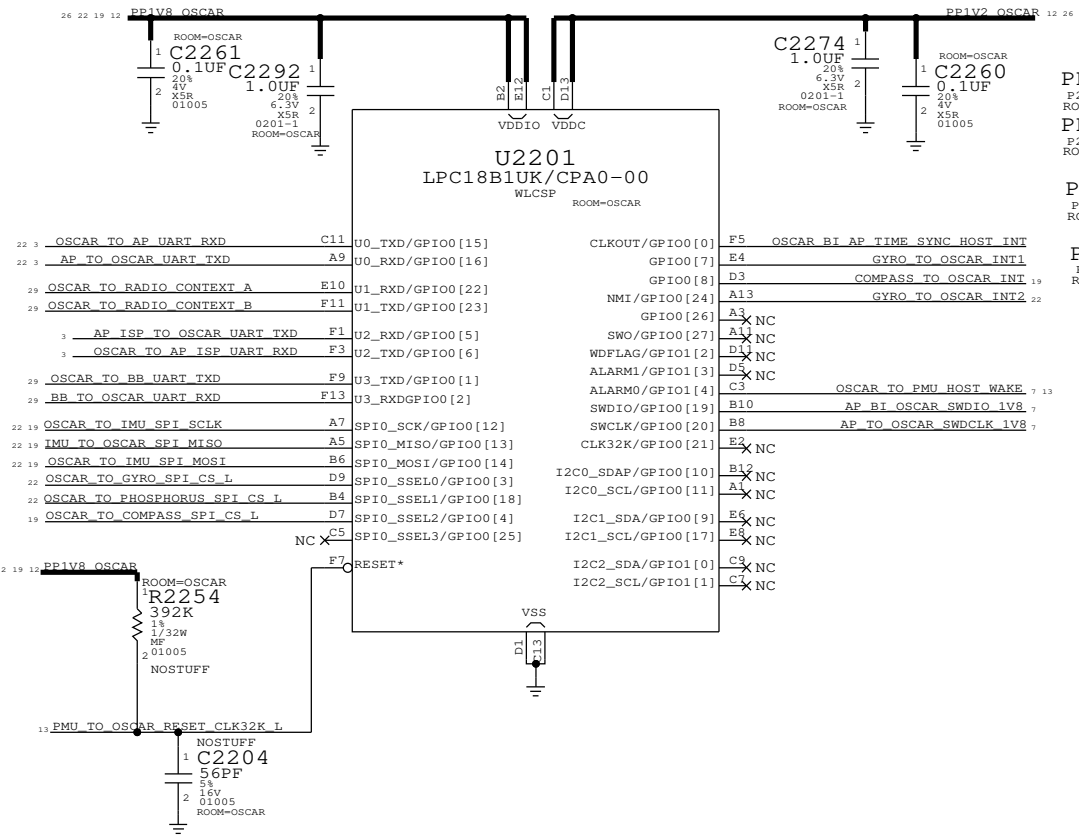

CARBON (ACCEL GYRO COMBO)

INVENSENSE, APN 338S00017, C2211=0.1UF
BOSCH, APN 338S00028, C2211=0.1UF
ST, APN 338S00029, C2211=0.01UF,25V

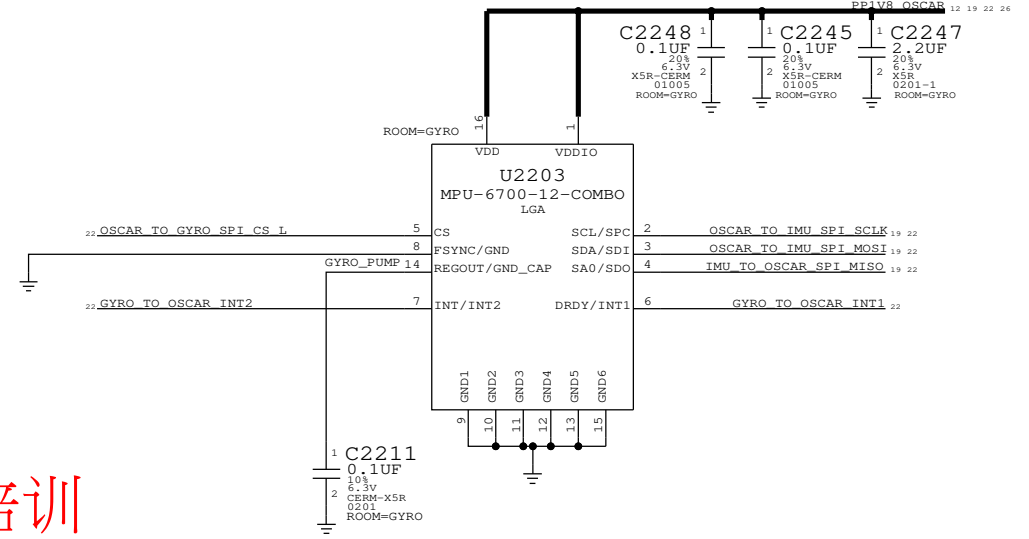

THIS IS OUTSIDE OF SHIELD IN TO THE RIGHT OF THE NAND

PHOSPHORUS

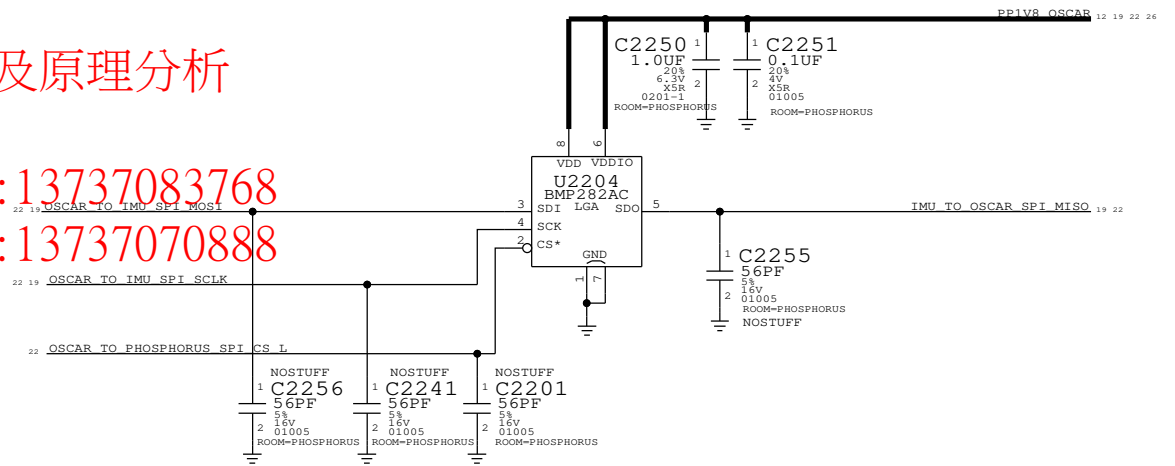

广西南宁功夫手机维修培训
修一切苹果 招天下学生
十年一线维修经验及教学经验

让学员们快速学会维修技术及原理分析
详情请加:
QQ: 343974077 翁老师电话: 13737083768
QQ: 344106191 王老师电话: 13737070888

SYNC MASTER=N61 MLB		SYNC DATE=08/26/2013	
PAGE TITLE SENSORS:OSCAR,CARBON,PHOS,MAGNESIUM			
DRAWING NUMBER 051-9903		SIZE D	
REVISION 7.0.0		BRANCH	
NOTICE OF PROPRIETARY PROPERTY: THE INFORMATION CONTAINED HEREIN IS THE PROPRIETARY PROPERTY OF APPLE INC. THE POSSESSOR AGREES TO THE FOLLOWING: I TO MAINTAIN THIS DOCUMENT IN CONFIDENCE II NOT TO REPRODUCE OR COPY IT III NOT TO REVEAL OR PUBLISH IT IN WHOLE OR PART IV ALL RIGHTS RESERVED			
PAGE 22 OF 55		SHEET 22 OF 54	

RCAM B2B (REAR CAMERA CONNECTOR)

RCAM:
4-LANE MIPI

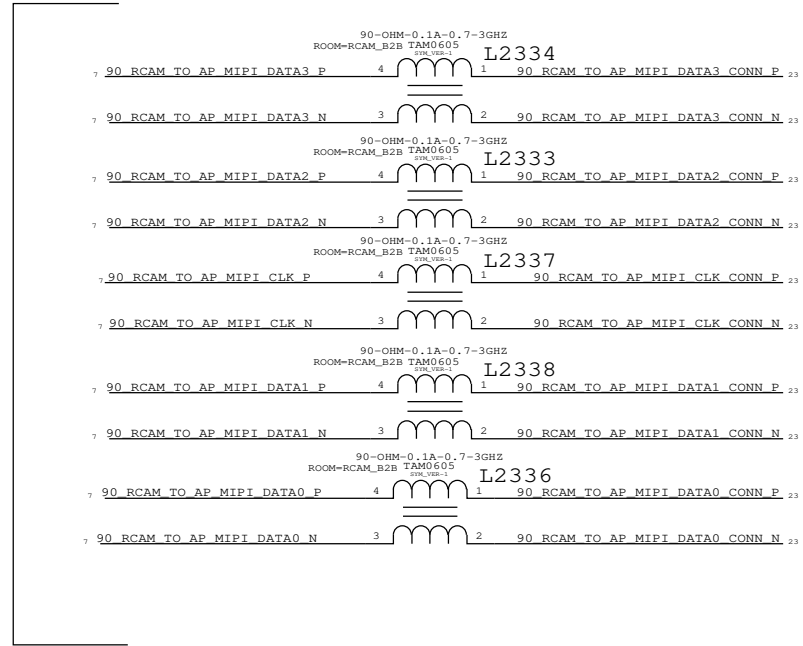

RCAM:
DIGITAL I/F
(I2C, CTRL, CLK)

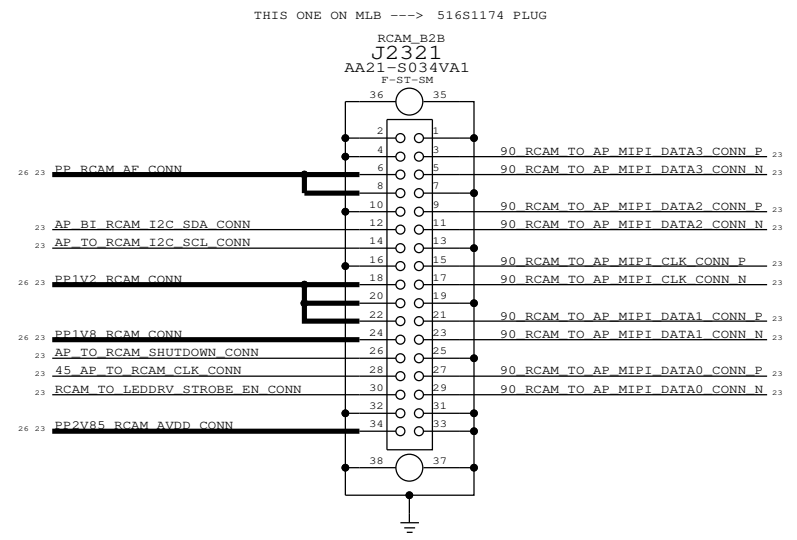
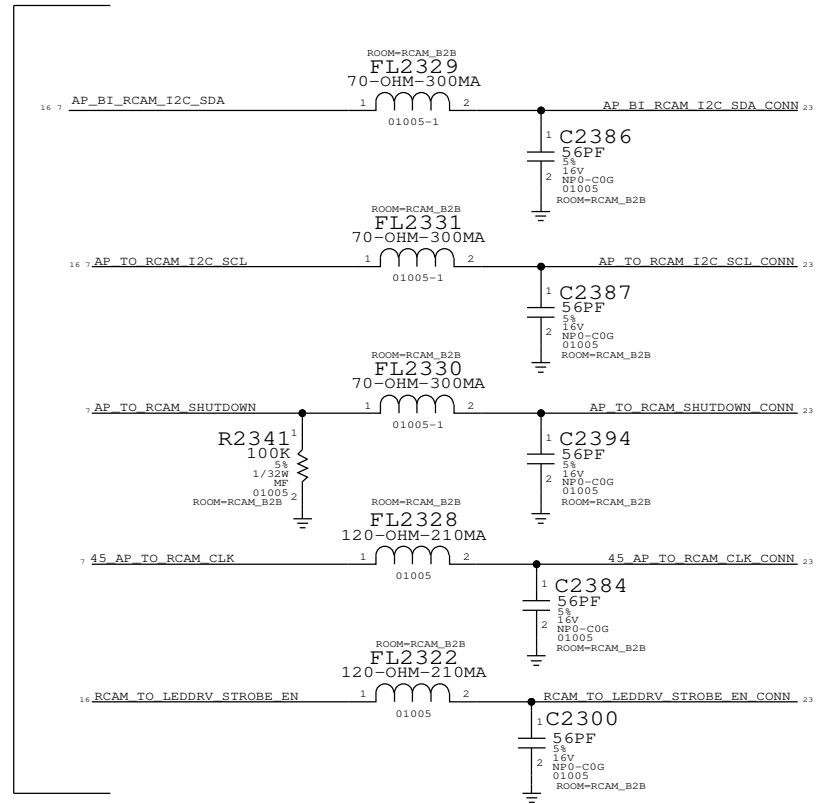

广西南宁功夫手机维修培训
修一切苹果 招天下学生
十年一线维修经验及教学经验

RCAM:
POWER:
(1.8V DVDD)
(2.8V AVDD)
(1.2V VCC)
(1.8V/2V AF)

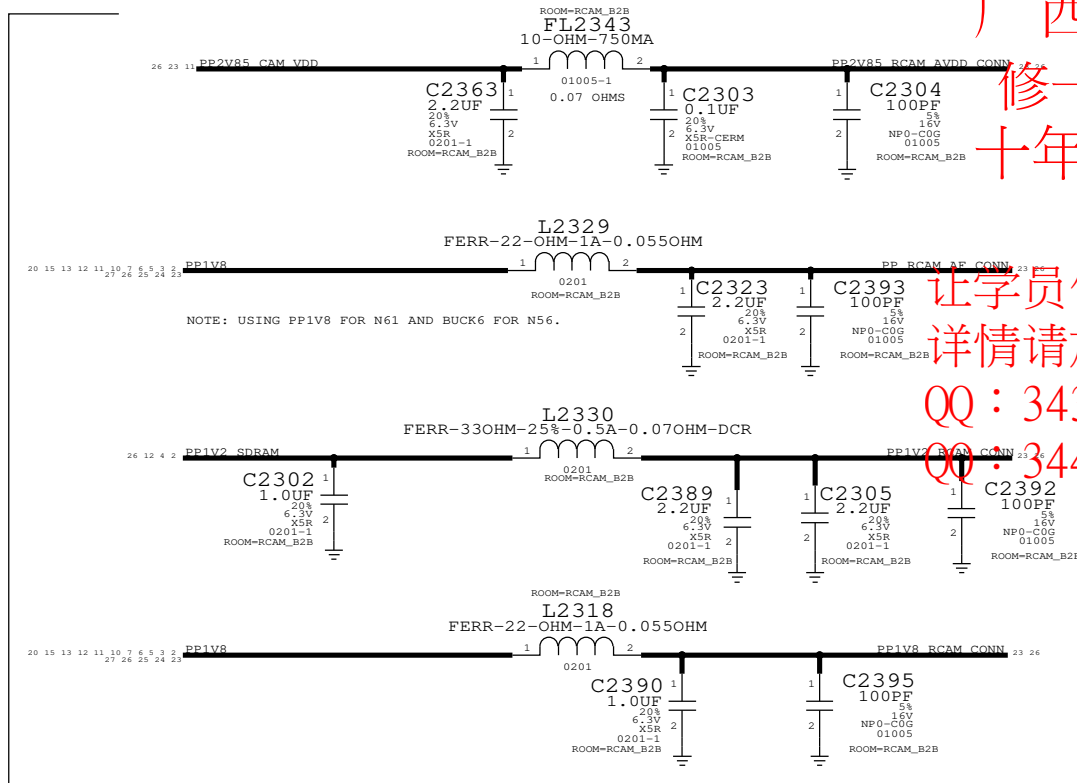

RCAM RCAM AVDD RAIL EXT. LDO:

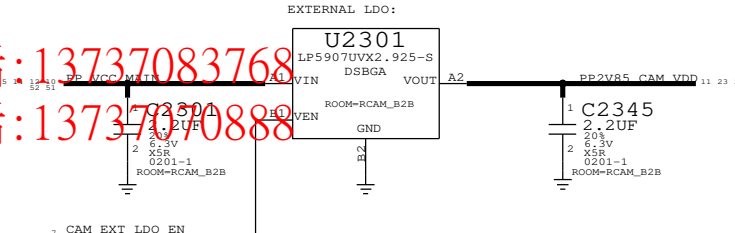

让学员们快速学会维修技术及原理分析
详情请加:
QQ: 343974077 翁老师电话: 13737083768
QQ: 344106191 王老师电话: 13737070888

SYNC MASTER=N61 MLB		SYNC DATE=08/26/2013	
CAMERA: REAR FLEX CONN			
Apple Inc.		DRAWING NUMBER	051-9903
		REVISION	7.0.0
NOTICE OF PROPRIETARY PROPERTY:		BRANCH	
THE INFORMATION CONTAINED HEREIN IS THE PROPRIETARY PROPERTY OF APPLE INC. THE POSSESSOR AGREES TO THE FOLLOWING:		PAGE	23 OF 55
I TO MAINTAIN THIS DOCUMENT IN CONFIDENCE		SHEET	23 OF 54
II NOT TO REPRODUCE OR COPY IT			
III NOT TO REVEAL OR PUBLISH IT IN WHOLE OR PART			
IV ALL RIGHTS RESERVED			

Touch (B2B, Driver ICs)

Cumulus

APN: 34350638

Turn on is later than PPIV8_GRAPE
Turn off is same time as PPIV8_GRAPE

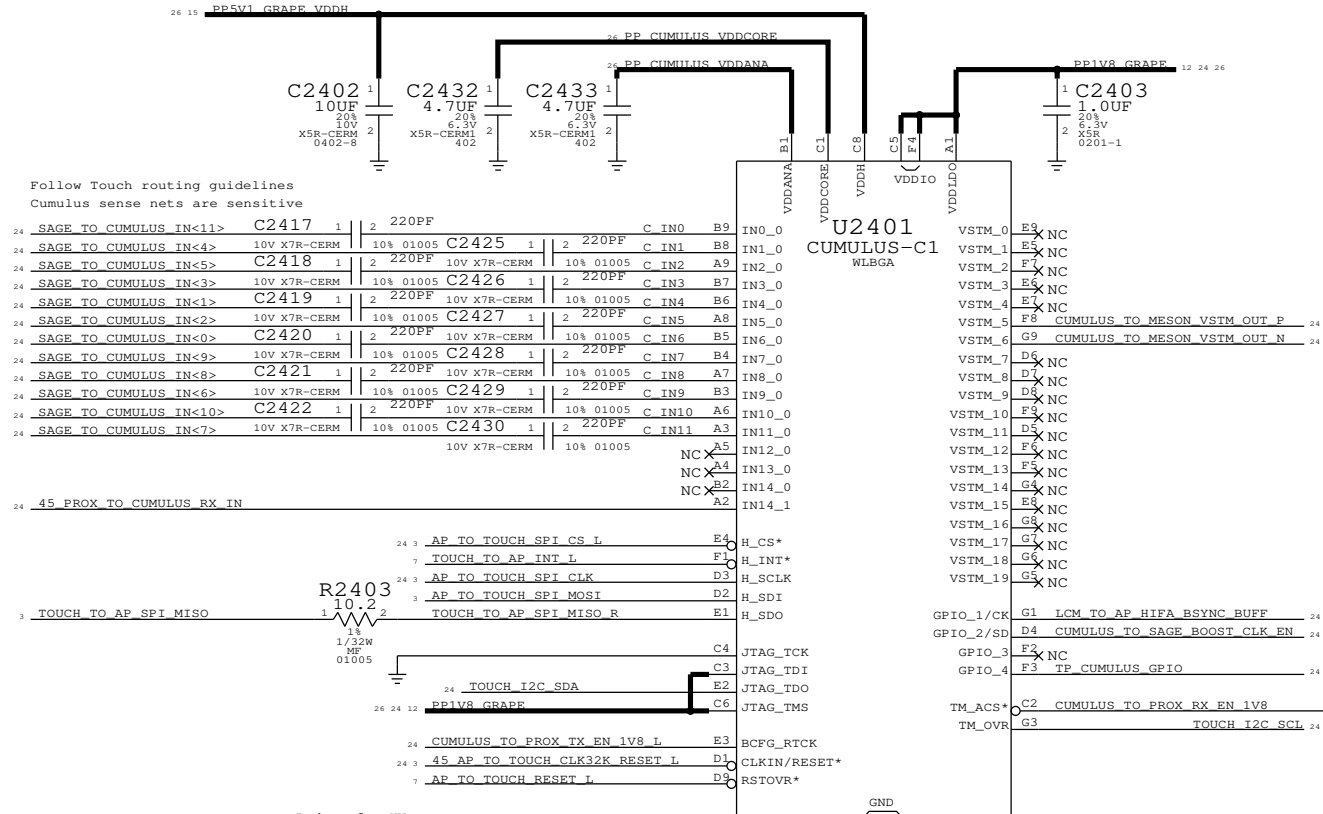

Touch B2B

MLB APN : 516S1086 (Receptacle)
Flex APN: 516S1087 (Plug)

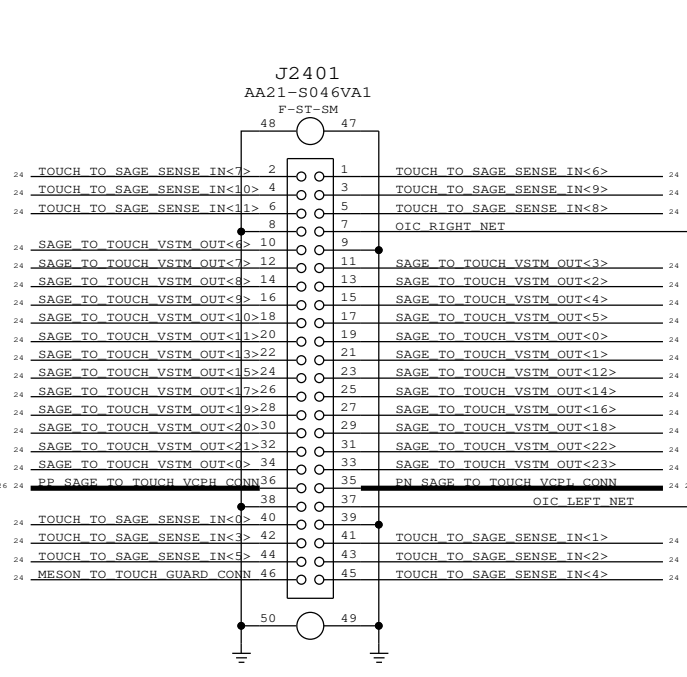

Touch probe points

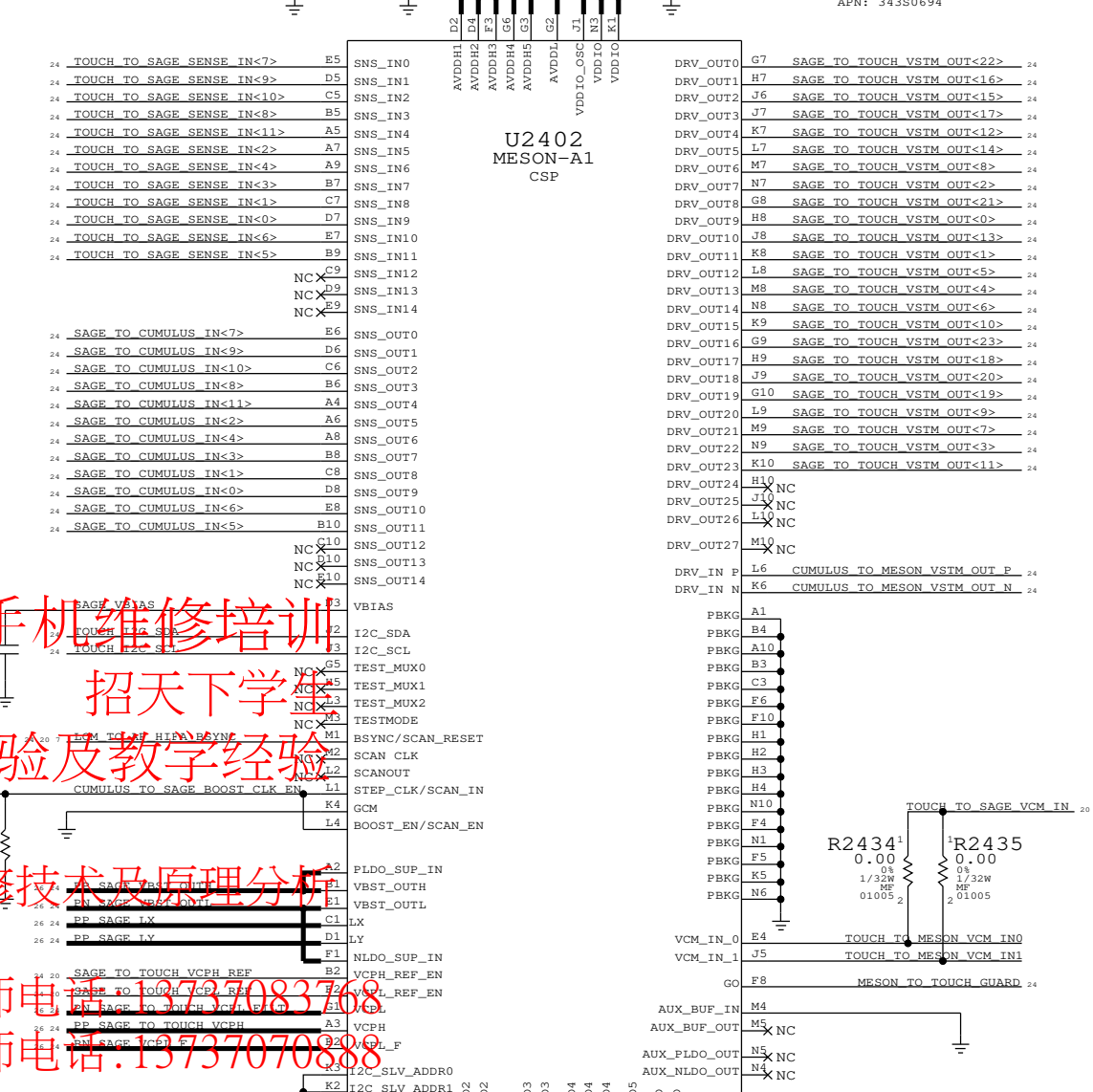
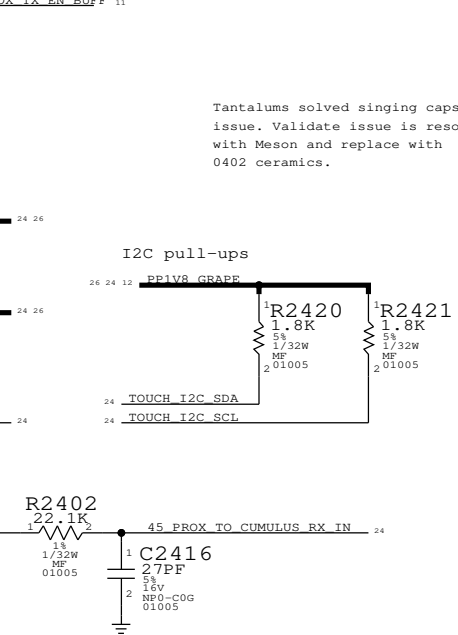
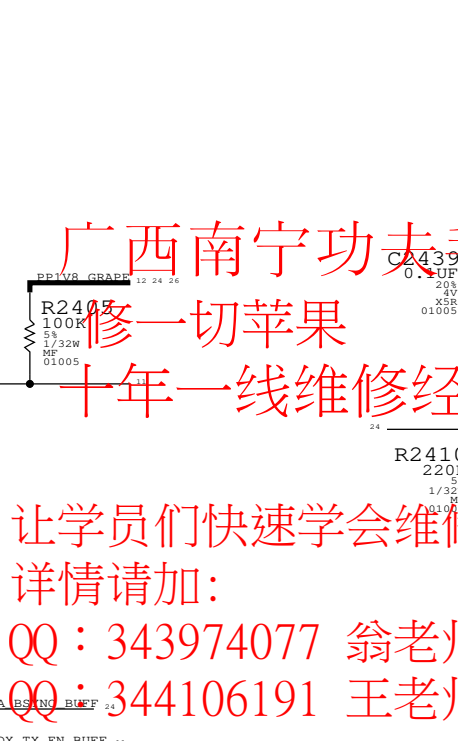
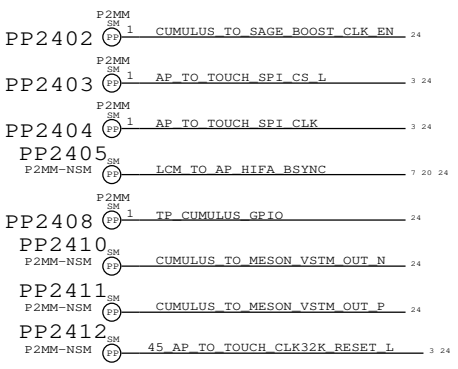

广西南宁功夫手机维修培训
修一切苹果
十年一线维修经验及教学经验
招天下学员
让学员们快速学会维修技术及原理分析
详情请加:
QQ: 343974077 翁老师电话: 13308370888
QQ: 344106191 王老师电话: 13737070888

TOUCH: CUMULUS, MESON	
Apple Inc.	DRAWING NUMBER: 051-9903
NOTICE OF PROPRIETARY PROPERTY:	REVISION: 7.0.0
THE INFORMATION CONTAINED HEREIN IS THE PROPRIETARY PROPERTY OF APPLE INC. THE POSSESSOR AGREES TO THE FOLLOWING:	PAGE: 24 OF 55
I TO MAINTAIN THIS DOCUMENT IN CONFIDENCE	SHEET: 24 OF 54
II NOT TO REPRODUCE OR COPY IT	
III NOT TO REVEAL OR PUBLISH IT IN WHOLE OR PART	
IV ALL RIGHTS RESERVED	

BATT CONN, TPS, STANDOFFS/SHIELDS/FIDUCIALS

D

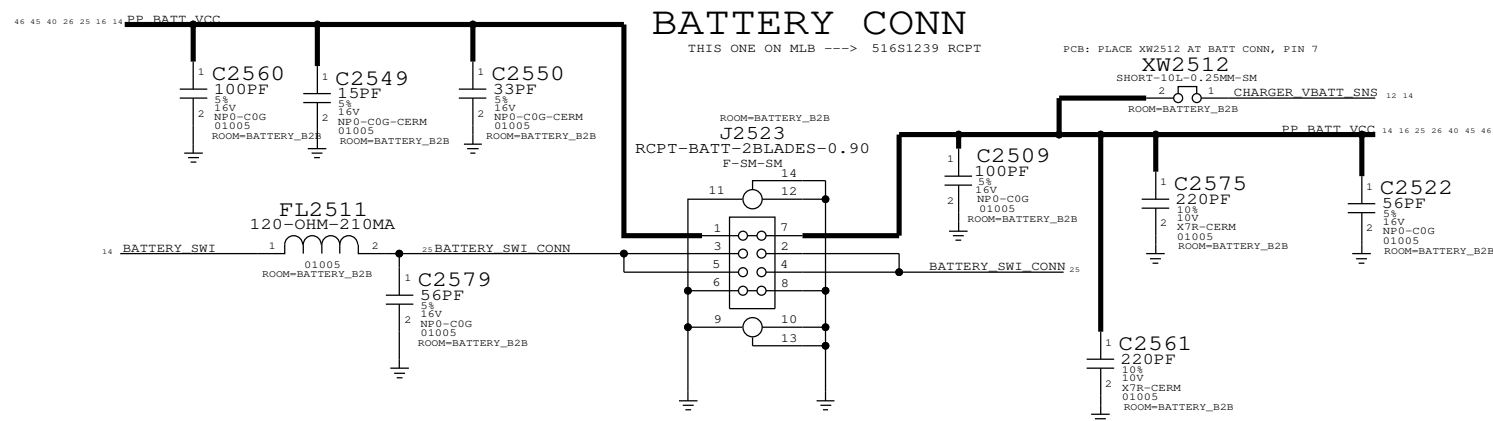

POWER TP

TESTPOINTS

MOJAVE TP

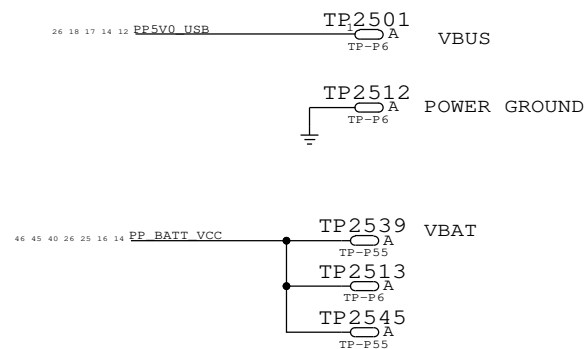

E75 - USB/UART/ID/POWER

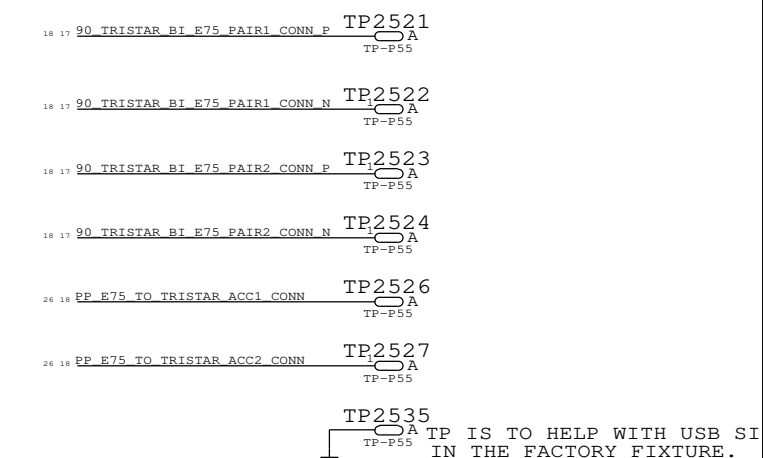

SUPER TP

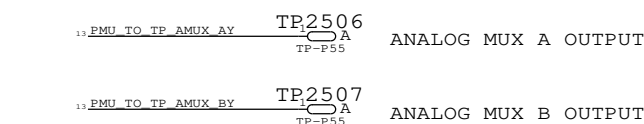

RESET

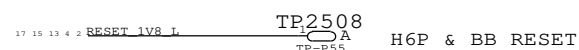

DFU

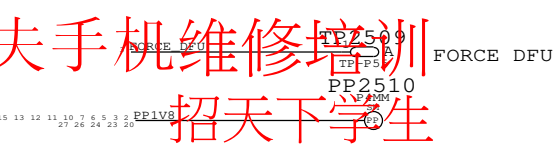

LCM BACKLIGHT

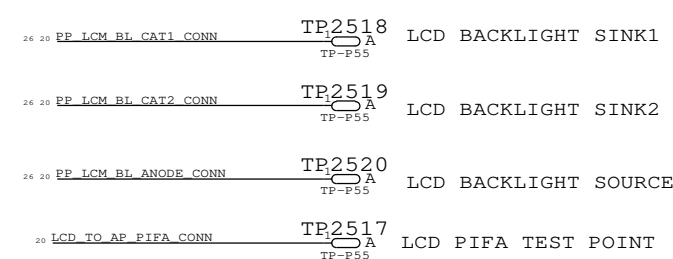

C

FIDUCIALS

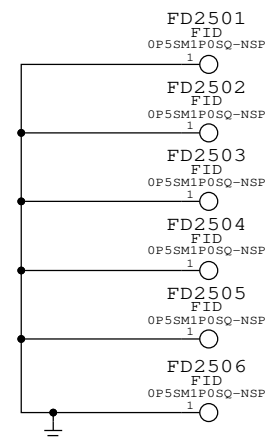

SHIELDS

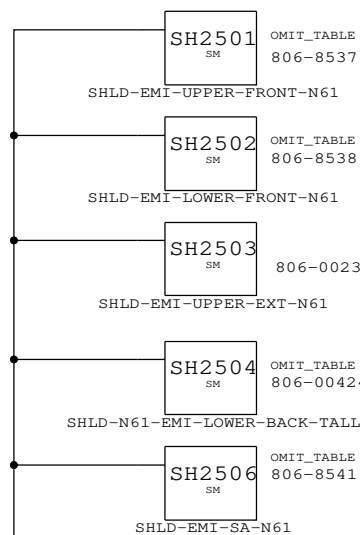

COWLING

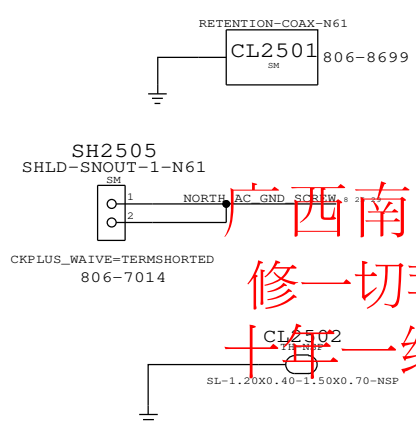

B

广西南宁功夫手机维修培训
 修一切苹果 招天下学生
 十年一线维修经验及教学经验
 让学员们快速学会维修技术及原理分析
 详情请加:
 QQ: 343974077 翁老师电话:13737083768
 QQ: 344106191 王老师电话:13737070888

SCREW HOLES + STANDOFFS

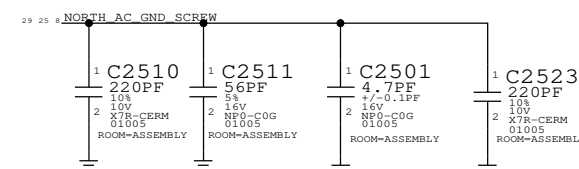
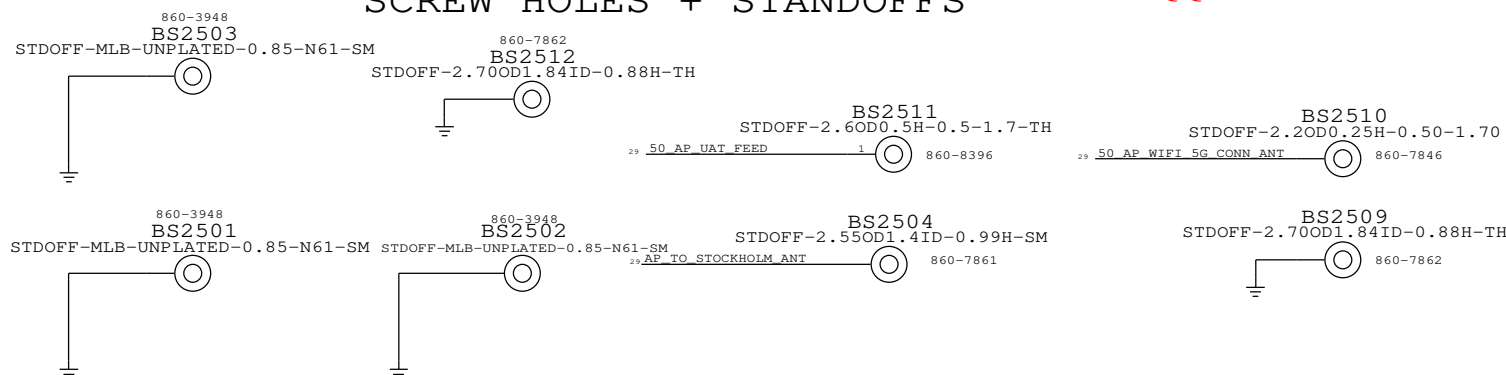

A

SYNC MASTER=N61 MLB		SYNC DATE=08/26/2013	
POWER:BATT CONN,TPS,PD FEATURES			
Apple Inc.		DRAWING NUMBER	051-9903
		REVISION	7.0.0
NOTICE OF PROPRIETARY PROPERTY:		BRANCH	
THE INFORMATION CONTAINED HEREIN IS THE PROPRIETARY PROPERTY OF APPLE, INC. THE POSSESSOR AGREES TO THE FOLLOWING:		PAGE	25 OF 55
I TO MAINTAIN THIS DOCUMENT IN CONFIDENCE		SHEET	25 OF 54
II NOT TO REPRODUCE OR COPY IT			
III NOT TO REVEAL OR PUBLISH IT IN WHOLE OR PART			
IV ALL RIGHTS RESERVED			

8

7

6

5

4

3

2

1

D

C

B

A

N61 SPECIFIC

BOOTSTRAPPING (BOARD_REV, BOARD_ID, BOOT_CFG)

```

BOARD_REV[3:0]={GPIO34, GPIO35, GPIO36, GPIO37}
FLOAT=LOW, PULLUP=HIGH
1111 PROTOMLB1
1110 PROTOMLB2
1101 PROTO1
1100 PROTO2
1011 EVT
1010 EVT SPLIT CARBON DOE
1001 CARRIER BUILD <--- SELECTED
1000 DVT

```

```

BOARD_ID[4:0]={GPIO29, GPIO16, SPI0_MISO, SPI0_MOSI, SPI0_SCLK}
FLOAT=LOW, PULLUP=HIGH
00100 N56, T133 MLB
00101 N56 DEV
00110 FIJI N61 MLB <--- SELECTED

```

```

BOOT_CONFIG[2:0]={GPIO28, GPIO25, GPIO18}
FLOAT=LOW, PULLUP=HIGH
000 SPI0
001 SPI0 TEST MODE
010 NAND <--- SELECTED
011 NAND TEST MODE
100 NVME
101 NVME TEST MODE
111 FAST SPI

```

广西南宁功夫手机维修培训
修一切苹果 招天下学生
十年一线维修经验及教学经验

让学员们快速学会维修技术及原理分析
详情请加:

QQ: 343974077 翁老师电话: 13737083768

QQ: 344106191 王老师电话: 15737070888

PAGE TITLE		
SYSTEM:N61 SPECIFIC		
Apple Inc.	DRAWING NUMBER	051-9903
	REVISION	7.0.0
NOTICE OF PROPRIETARY PROPERTY: THE INFORMATION CONTAINED HEREIN IS THE PROPRIETARY PROPERTY OF APPLE, INC. THE POSSESSOR AGREES TO THE FOLLOWING: I TO MAINTAIN THIS DOCUMENT IN CONFIDENCE II NOT TO REPRODUCE OR COPY IT III NOT TO REVEAL OR PUBLISH IT IN WHOLE OR PART IV ALL RIGHTS RESERVED	BRANCH	
	PAGE	27 OF 55
	SHEET	27 OF 54

广西南宁功夫手机维修培训
修一切苹果 招天下学生
十年一线维修经验及教学经验

让学员们快速学会维修技术及原理分析
详情请加：

QQ：343974077 翁老师电话：13737083768

QQ：344106191 王老师电话：13737070888

PAGE TITLE		BLANK	
 Apple Inc.	DRAWING NUMBER	051-9903	SIZE
	REVISION	7.0.0	D
NOTICE OF PROPRIETARY PROPERTY:		BRANCH	
THE INFORMATION CONTAINED HEREIN IS THE PROPRIETARY PROPERTY OF APPLE, INC. THE POSSESSOR AGREES TO THE FOLLOWING:		PAGE	
I TO MAINTAIN THIS DOCUMENT IN CONFIDENCE		28 OF 55	
II NOT TO REPRODUCE OR COPY IT		SHEET	
III NOT TO REVEAL OR PUBLISH IT IN WHOLE OR PART		28 OF 54	
IV ALL RIGHTS RESERVED			

RADIO_MLB HIERARCHICAL SYMBOL

POWER

VCC_MAIN, VBAT GOES TO RADIO_MLB DIRECTLY
CHECK ALL PAGES IN RF SIDE!

CELLULAR HOUSE KEEPING

Table with columns: Signal Name, MAKE_BASE-TRUE, Value, Target Name, Target Value, Target Type. Includes signals like AP_TO_RADIO_ON_L, BB_TO_AP_RESET_DET_L, etc.

HSIC IPC

Table with columns: Signal Name, MAKE_BASE-TRUE, Value, Target Name, Target Value, Target Type. Includes signals like 50_AP_BI_BB_HSIC1_DATA, 50_BB_HSIC_DATA, etc.

UART IPC

Table with columns: Signal Name, MAKE_BASE-TRUE, Value, Target Name, Target Value, Target Type. Includes signals like AP_TO_BB_UART2_RTS_L, BB_UART2_RTS_L, etc.

AUDIO I2S

Table with columns: Signal Name, MAKE_BASE-TRUE, Value, Target Name, Target Value, Target Type. Includes signals like 45_AP_TO_BB_I2S3_BCLK, BB_I2S_CLK, etc.

OSCAR UART

Table with columns: Signal Name, MAKE_BASE-TRUE, Value, Target Name, Target Value, Target Type. Includes signals like OSCAR_TO_BB_UART_TXD, BB_UART_TXD, etc.

BB DEBUG INTERFACES

Table with columns: Signal Name, MAKE_BASE-TRUE, Value, Target Name, Target Value, Target Type. Includes signals like AP_TO_BB_COREDUMP, BB_CORE_DUMP, etc.

RADIO ANTENNA CONTROL

Table with columns: Signal Name, MAKE_BASE-TRUE, Value, Target Name, Target Value, Target Type. Includes signals like PP_BB_VDD_2V7, PP_LDO14_RFSW, etc.

FCT TESTING

Table with columns: Signal Name, MAKE_BASE-TRUE, Value, Target Name, Target Value, Target Type. Includes signals like RADIO_TO_PMU_ADC_SMP51, ADC_SMP51, etc.

UPPER RADIO ANTENNA CONTROL

Table with columns: Signal Name, MAKE_BASE-TRUE, Value, Target Name, Target Value, Target Type. Includes signals like 50_AP_WIFI_5G_CONN_ANT, 50_UPPER_ANT_FEED, etc.

POWER



WLAN/BT HOUSE KEEPING

Table with columns: Signal Name, MAKE_BASE-TRUE, Value, Target Name, Target Value, Target Type. Includes signals like 45_PMU_TO_WLAN_CLK32K, CLK32K_AP, etc.

Table with columns: Signal Name, MAKE_BASE-TRUE, Value, Target Name, Target Value, Target Type. Includes signals like AP_TO_WLAN_JTAG_SWCLK, WLAN_JTAG_SWCLK, etc.

WLAN HSIC IPC

Table with columns: Signal Name, MAKE_BASE-TRUE, Value, Target Name, Target Value, Target Type. Includes signals like WLAN_TO_BB_UART4_RXD, WLAN_UART_RXD, etc.

BT UART IPC

Table with columns: Signal Name, MAKE_BASE-TRUE, Value, Target Name, Target Value, Target Type. Includes signals like AP_TO_BT_UART1_RTS_L, BT_UART_CTS_L, etc.

BT AUDIO PCM

Table with columns: Signal Name, MAKE_BASE-TRUE, Value, Target Name, Target Value, Target Type. Includes signals like 45_AP_TO_BT_I2S1_BCLK, BT_PCM_CLK, etc.

OSCAR STATES

Table with columns: Signal Name, MAKE_BASE-TRUE, Value, Target Name, Target Value, Target Type. Includes signals like OSCAR_TO_RADIO_CONTEXT_A, OSCAR_CONTEXT_A, etc.

STOCKHOLM

Table with columns: Signal Name, MAKE_BASE-TRUE, Value, Target Name, Target Value, Target Type. Includes signals like STOCKHOLM_TO_AP_UART3_CTS_L, STOCKHOLM_RTS_L, etc.

南宁功夫手机维修培训
修一切苹果
十年一线维修经验及教学经验

让学员们快速学会维修技术及原理分析
详情请加:
QQ: 343974077 翁老师电话: 13737083768
QQ: 344106191 王老师电话: 13737070888

CELL:ALIASES
Apple Inc.
DRAWING NUMBER: 051-9903
REVISION: 7.0.0
PAGE: 30 OF 55
SHEET: 29 OF 54

AP INTERFACE & DEBUG CONNECTORS

PROBE POINTS

PP3105_RF P2MM-NSM SM 1 CLK32K_AP 29 51	PP3121_RF P2MM-NSM SM 1 STOCKHOLM_HOST_WAKE 29 52	PP3115_RF P4MM-NSM SM 1 50_BB_HSIC_STROBE 29 34	PP3130_RF P4MM-NSM SM 1 BB_JTAG_RST_L 29 34	PP3141_RF P4MM-NSM SM 1 BB_UART_TXD 29 35	PP3170_RF P4MM-NSM SM 1 RFFE1_CLK 35 39 40 41 42 43 44
PP3113_RF P4MM-NSM SM 1 BB_COEX_UART_RXD 35 51	PP3122_RF P4MM-NSM SM 1 BB_REQUEST_XO_CLK 32 52	PP3116_RF P4MM-NSM SM 1 50_BB_HSIC_DATA 29 34	PP3131_RF P4MM-NSM SM 1 BB_JTAG_TCK 29 34	PP3142_RF P4MM-NSM SM 1 BB_UART_RXD 29 35	PP3171_RF P4MM-NSM SM 1 RFFE1_DATA 35 39 40 41 42 43 44
PP3114_RF P4MM-NSM SM 1 BB_COEX_UART_TXD 35 51	PP3123_RF P2MM-NSM SM 1 STOCKHOLM_UART_RXD 29 52	PP3101_RF P4MM-NSM SM 1 BB_DEBUG_ERROR 35	PP3132_RF P4MM-NSM SM 1 BB_JTAG_TMS 29 34	PP3143_RF P4MM-NSM SM 1 BB_UART_RTS_L 29 35	PP3172_RF P4MM-NSM SM 1 RFFE2_CLK 35 45 46 48
PP3119_RF P2MM-NSM SM 1 BT_UART_TXD 29 51	PP3124_RF P2MM-NSM SM 1 STOCKHOLM_UART_TXD 29 52	PP3102_RF P4MM-NSM SM 1 RF_PMIC_RESET_L 29 32	PP3133_RF P4MM-NSM SM 1 BB_JTAG_TDO 29 34	PP3144_RF P4MM-NSM SM 1 BB_UART_CTS_L 29 35	PP3173_RF P4MM-NSM SM 1 RFFE2_DATA 35 45 46 48
PP3120_RF P2MM-NSM SM 1 BT_UART_RXD 29 51	PP3125_RF P2MM-NSM SM 1 STOCKHOLM_CTS_L 29 52	PP3103_RF P4MM-NSM SM 1 FS_HOLD_PMIC 32	PP3134_RF P4MM-NSM SM 1 BB_JTAG_TDI 29 34	PP3145_RF P4MM-NSM SM 1 BB_HOST_RDY 29 35	PP3175_RF P4MM-NSM SM 1 BB_I2S_WS 29 35
PP3152_RF P4MM-NSM SM 1 WAKE_BT 29 51	PP3126_RF P2MM-NSM SM 1 STOCKHOLM_RTS_L 29 52	PP3127_RF P4MM-NSM SM 1 PMIC_RESOUT_L 32 34	PP3135_RF P4MM-NSM SM 1 BB_JTAG_TRST_L 29 34	PP3146_RF P4MM-NSM SM 1 BB_DEVICE_RDY 29 35	PP3176_RF P4MM-NSM SM 1 BB_I2S_RXD 29 35
PP3153_RF P4MM-NSM SM 1 WLAN_REG_ON 29 51	PP3128_RF P4MM-NSM SM 1 PP_PN65_VCC_SIM 52	PP3104_RF P4MM-NSM SM 1 MDM_CLK 32 34	PP3136_RF P4MM-NSM SM 1 BB_DEBUG_STATUS 29 35	PP3147_RF P4MM-NSM SM 1 BB_WAKE_HOST_L 29 35	PP3177_RF P4MM-NSM SM 1 BB_I2S_TXD 29 35
PP3154_RF P4MM-NSM SM 1 BT_REG_ON 29 51	PP3114_RF P4MM-NSM SM 1 STOCKHOLM_SIM_SWP 52 54	PP3109_RF P4MM-NSM SM 1 PP_LDO11 30 31 33	PP3137_RF P4MM-NSM SM 1 BB_PORF_TIMER 29 35	PP3148_RF P4MM-NSM SM 1 BB_WAKE_HOST_L 29 35	PP3178_RF P4MM-NSM SM 1 BB_OTHER_TXD 29 35
PP3155_RF P4MM-NSM SM 1 HOST_WAKE_WLAN 29 51	PP3129_RF P4MM-NSM SM 1 REF_CLK_FROM_BB 32 52	PP3110_RF P4MM-NSM SM 1 RADIO_ON_L 29 32	PP3138_RF P4MM-NSM SM 1 BB_USF_CTS 29 34	PP3149_RF P4MM-NSM SM 1 BB_RST_L 29 32	PP3179_RF P4MM-NSM SM 1 BB_OTHER_RXD 29 35
PP3156_RF P4MM-NSM SM 1 WLAN_PCIE_WAKE_L 29 51	PP3165_RF P4MM-NSM SM 1 DSDS_SIM_CLK 34 54	PP3111_RF P4MM-NSM SM 1 SPMI_DATA 32 34	PP3139_RF P4MM-NSM SM 1 90_BB_USB_N 29 34	PP3150_RF P4MM-NSM SM 1 BOOT_HSIC 30 35	
PP3157_RF P4MM-NSM SM 1 WLAN_PCIE_PERST_L 29 51	PP3183_RF P4MM-NSM SM 1 DSDS_SIM_RESET 34 54	PP3112_RF P4MM-NSM SM 1 SPMI_CLK 32 34	PP3140_RF P4MM-NSM SM 1 90_BB_USB_P 29 34		
PP3158_RF P4MM-NSM SM 1 WLAN_PCIE_CLKREQ_L 29 51	PP3184_RF P4MM-NSM SM 1 DSDS_SIM_DATA 34 54				
PP3159_RF P4MM-NSM SM 1 PCIE_DEV_WAKE 29 51	PP3187_RF P4MM-NSM SM 1 PP_LDO6 31 33 54				
PP3160_RF P4MM-NSM SM 1 WLAN_UART_RTS_L 29 51	PP3188_RF P4MM-NSM SM 1 DSDS_SIM_SWP 54				
PP3161_RF P4MM-NSM SM 1 WLAN_UART_CTS_L 29 51	PP3189_RF P4MM-NSM SM 1 DSDS_SIM_DATA_R 54				
PP3162_RF P4MM-NSM SM 1 WLAN_UART_RXD 29 51	PP 3178_RF P2MM-NSM SM 1 BB_SIM_RESET 30 35				
PP3163_RF P4MM-NSM SM 1 WLAN_UART_TXD 29 51	PP 3179_RF P2MM-NSM SM 1 BB_SIM_CLK 30 35				
PP3190_RF P2MM-NSM SM 1 WLAN_JTAG_SWDCCLK 29 51	PP 3180_RF P2MM-NSM SM 1 BB_SIM_DATA 30 35				
PP3191_RF P2MM-NSM SM 1 WLAN_JTAG_SWDIO 29 51	PP 3183_RF P2MM-NSM SM 1 BB_SIM_DETECT 30 35				
	PP 3184_RF P2MM-NSM SM 1 PP_LDO5 30 31 33 54				

广西南宁功夫手机维修培训
修一切苹果
十年一线维修经验及教学经验

让学员们快速学会维修技术及原理分析
详情请加：
QQ: 343974077 翁老师电话: 13737083768
QQ: 344106191 王老师电话: 13737070888

PART NUMBER	ALTERNATE PART NUMBER	HOW OBTAIN	REF. REF.	COMMENTS
197S0565	197S0593	ALTERNATE	Y3301_RF	K05 19.2MHz XTAL
197S0598	197S0593	ALTERNATE	Y6301_RF	AVX18.2MHz XTAL
138S00005	138S00000	ALTERNATE	C3216_RF	1500 CAPACITOR
138S0739	138S0706	ALTERNATE	C4207_RF	1.00UF CAPACITOR
138S0945	138S0706	ALTERNATE	C4207_RF	1.00UF CAPACITOR
138S1103	138S0719	ALTERNATE	C4007_RF	4.7UF CAPACITOR
339S0231	339S0228	ALTERNATE	U5201_RF	CORONA MODULE USI
339S0242	339S0228	ALTERNATE	U5201_RF	CORONA MODULE TDK
155S00024	155S0950	ALTERNATE	F_TRI_RF	TRIPLEXER BIN2

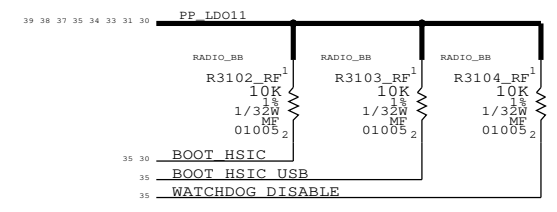

SIM CARD ESD PROTECTION

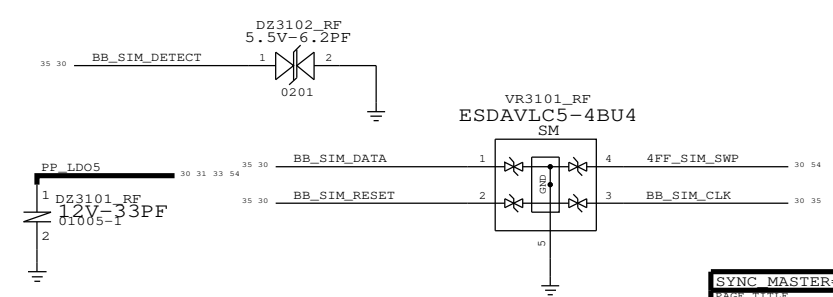

SIM CARD CONNECTOR

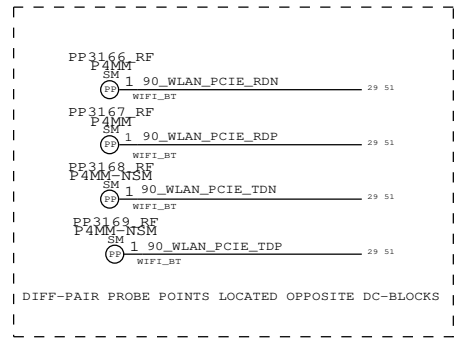
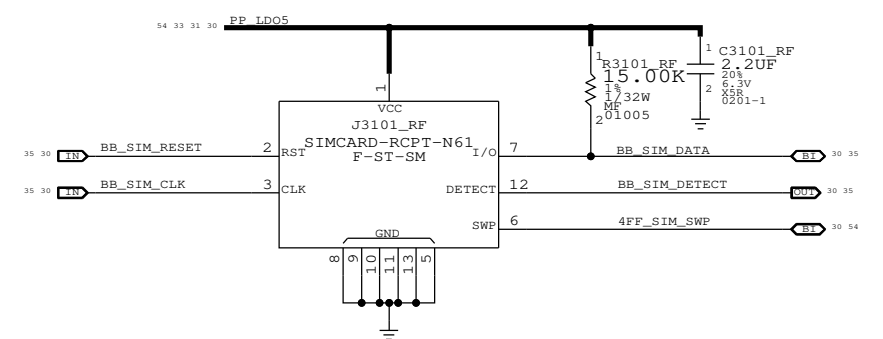

33 31	XW3101_RF SHORT-10L-0.1MM-SM 1 0 2 ADC_SMPS1	29
38 37 35 34 33 32 31	PP_LDO11 SHORT-10L-0.1MM-SM 1 0 2 ADC_PP_LDO11	29
54 33 31 30	PP_LDO5 SHORT-10L-0.1MM-SM 1 0 2 ADC_PP_LDO5	29
31	XW3104_RF SHORT-10L-0.1MM-SM 1 0 2 ADC_SMPS4	29

SYNC MASTER=N/A SYNC DATE=N/A

AP INTERFACE & DEBUG CONNECTORS

Apple Inc.

051-9903 D

7.0.0

NOTICE OF PROPRIETARY PROPERTY:
THE INFORMATION CONTAINED HEREIN IS THE PROPRIETARY PROPERTY OF APPLE INC. THE POSSESSOR AGREES TO THE FOLLOWING:
I TO MAINTAIN THIS DOCUMENT IN CONFIDENCE
I NOT TO REPRODUCE OR COPY IT
I NOT TO REVEAL OR PUBLISH IT IN WHOLE OR PART
I V ALL RIGHTS RESERVED

31 OF 55

30 OF 54

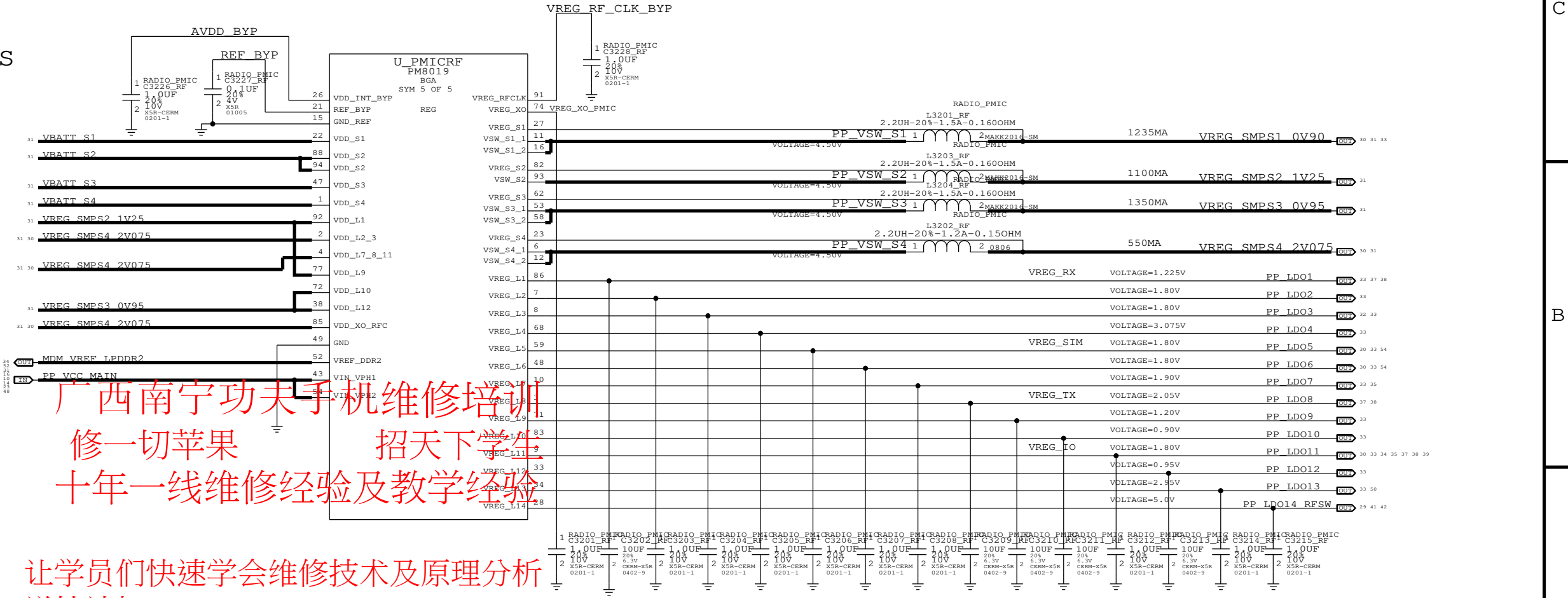
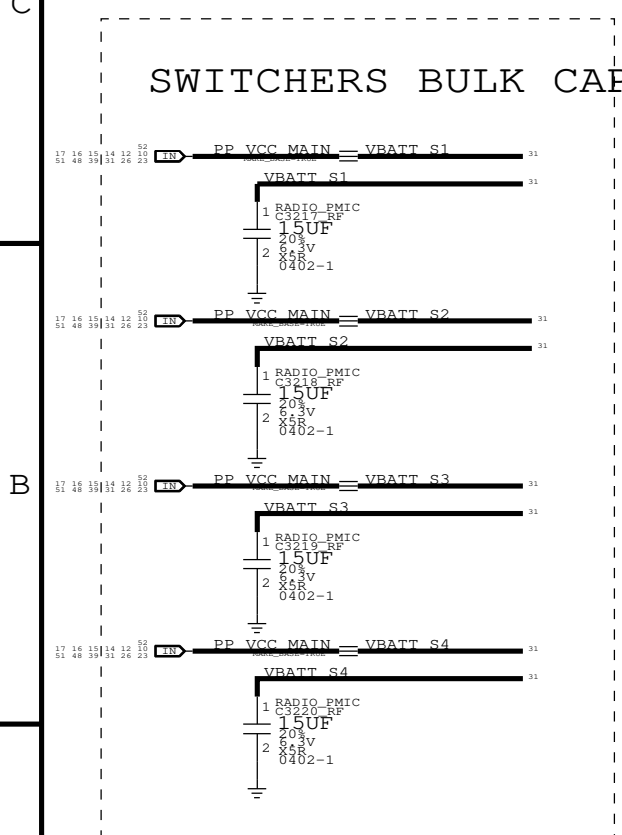
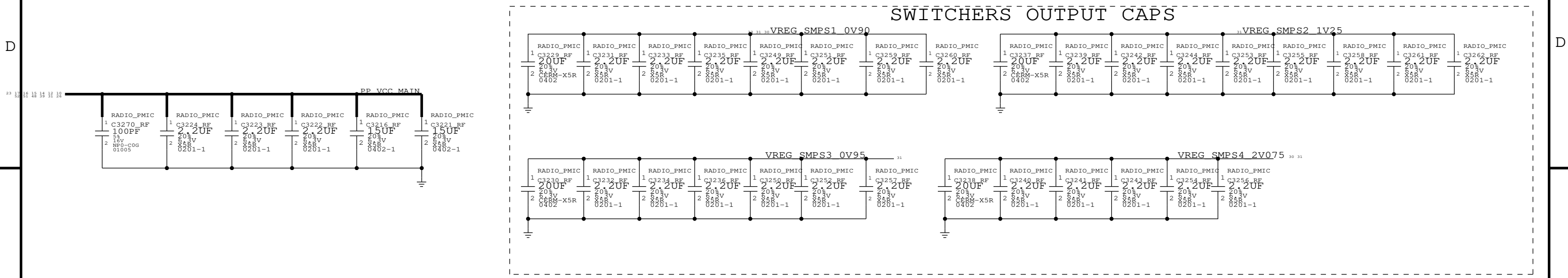

广西南宁功夫手机维修培训
 修一切苹果 招天下学生
 十年一线维修经验及教学经验

让学员们快速学会维修技术及原理分析
 详情请加：
 QQ：343974077 翁老师电话：13737083768
 QQ：344106191 王老师电话：13737070888

BASEBAND PMU (1 OF 2)	
Apple Inc.	DRAWING NUMBER: 051-9903 D
	REVISION: 7.0.0
NOTICE OF PROPRIETARY PROPERTY: THE INFORMATION CONTAINED HEREIN IS THE PROPRIETARY PROPERTY OF APPLE, INC. THE POSSESSOR AGREES TO THE FOLLOWING: I TO MAINTAIN THIS DOCUMENT IN CONFIDENCE II NOT TO REPRODUCE OR COPY IT III NOT TO REVEAL OR PUBLISH IT IN WHOLE OR PART IV ALL RIGHTS RESERVED	BRANCH: PAGE: 32 OF 55 SHEET: 31 OF 54

BASEBAND PMU (2 OF 2)

CONFIDENTIAL AND PROPRIETARY APPLE SYSTEM DESIGN. FOR REFERENCE PURPOSES ONLY - NOT A CHANGE REQUEST.

1
C401
R411
L400
U404

BOARD ID	REVISION
0.00V	N61 PROTO_MLB1
0.50V	N61 DEV3
0.70V	N61 DEV4
0.90V	N61 PROTO_MLB2
1.10V	N61/N56 PROTO1
1.30V	N61/N56 PROTO2
1.40V	N61/N56 EVT1
1.50V	N61/N56 EVT2 (CARRIER)
1.60V	N61/N56 DVT
1.70V	N61/N56 PVT

C

B

A

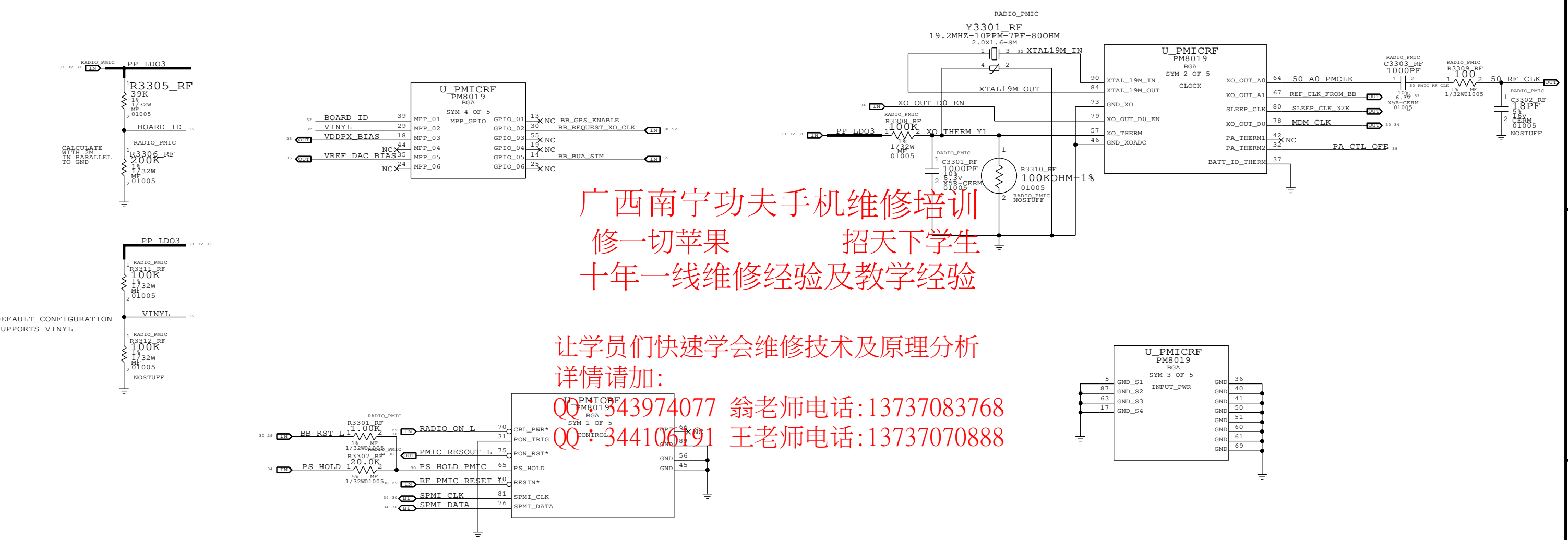

广西南宁功夫手机维修培训
修一切苹果 招天下学生
十年一线维修经验及教学经验

让学员们快速学会维修技术及原理分析
详情请加：
QQ: 343974077 翁老师电话: 13737083768
QQ: 344106191 王老师电话: 13737070888

BASEBAND PMU (2 OF 2)	
Apple Inc.	DRAWING NUMBER: 051-9903 D
	REVISION: 7.0.0
NOTICE OF PROPRIETARY PROPERTY: THE INFORMATION CONTAINED HEREIN IS THE PROPRIETARY PROPERTY OF APPLE, INC. THE POSSESSOR AGREES TO THE FOLLOWING: I TO MAINTAIN THIS DOCUMENT IN CONFIDENCE II NOT TO REPRODUCE OR COPY IT III NOT TO REVEAL OR PUBLISH IT IN WHOLE OR PART IV ALL RIGHTS RESERVED	BRANCH: 33 OF 55 PAGE: 32 OF 54

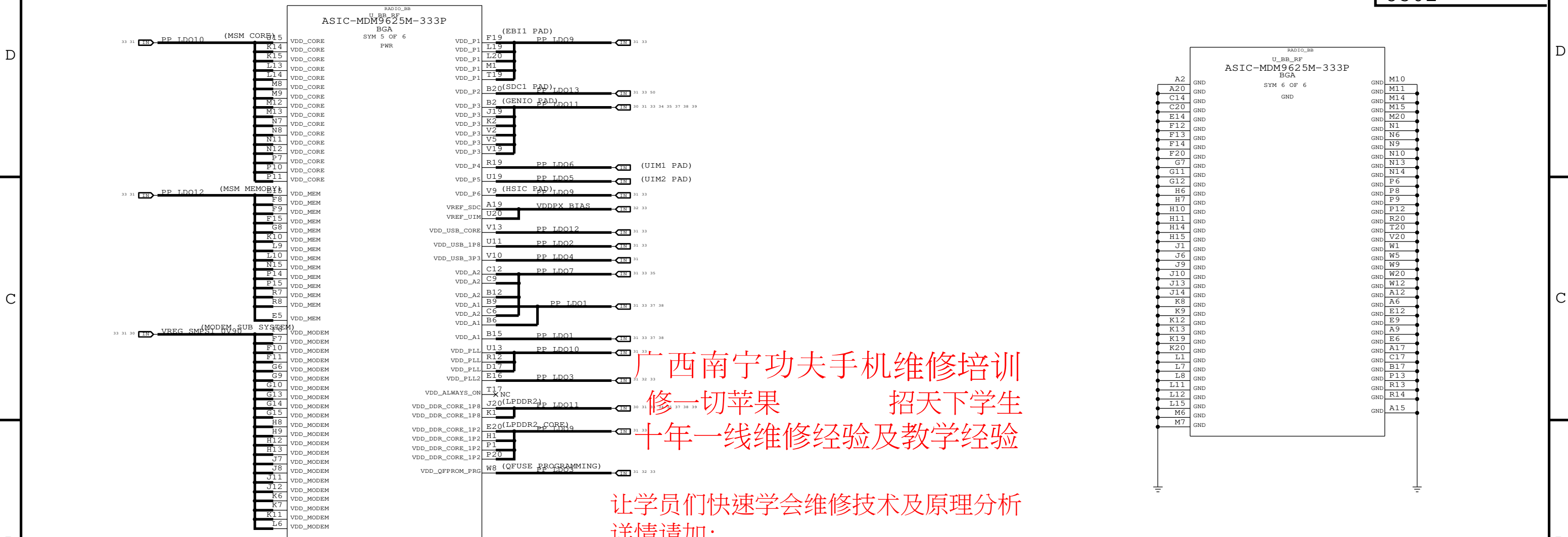

广西南宁功夫手机维修培训
 修一切苹果 招天下学生
 十年一线维修经验及教学经验

让学员们快速学会维修技术及原理分析
 详情请加:

QQ: 343974077 翁老师电话: 13737083768
 QQ: 344106191 王老师电话: 13737070888

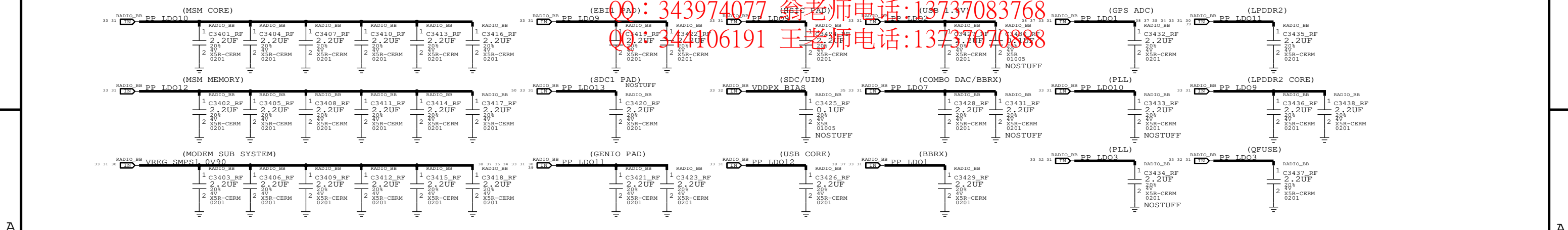

PAGE TITLE BASEBAND (1 OF 2)	
Apple Inc.	DRAWING NUMBER 051-9903 D
	REVISION 7.0.0
NOTICE OF PROPRIETARY PROPERTY: THE INFORMATION CONTAINED HEREIN IS THE PROPRIETARY PROPERTY OF APPLE INC. THE POSSESSOR AGREES TO THE FOLLOWING: I TO MAINTAIN THIS DOCUMENT IN CONFIDENCE II NOT TO REPRODUCE OR COPY IT III NOT TO REVEAL OR PUBLISH IT IN WHOLE OR PART IV ALL RIGHTS RESERVED	
PAGE 34 OF 55	SHEET 33 OF 54

1
C600
R606
L600
U602

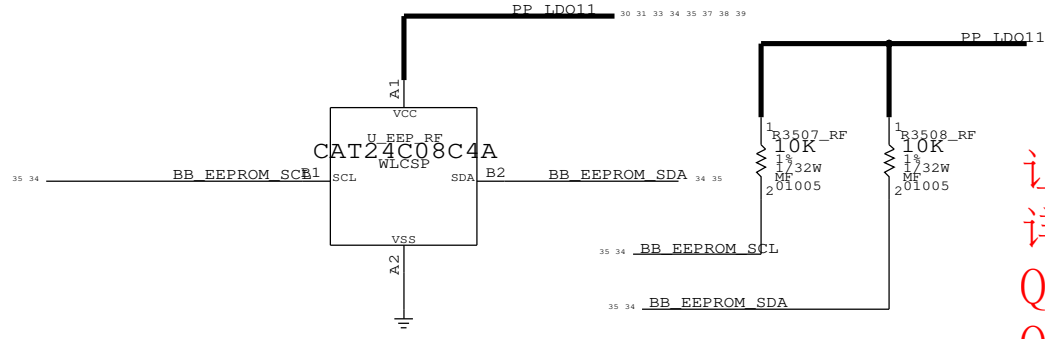
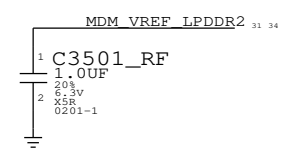
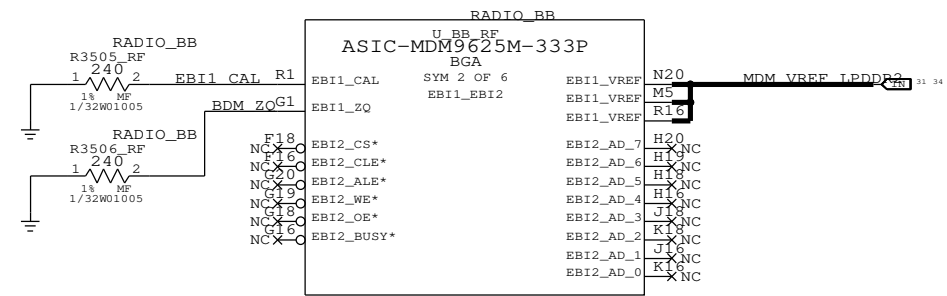
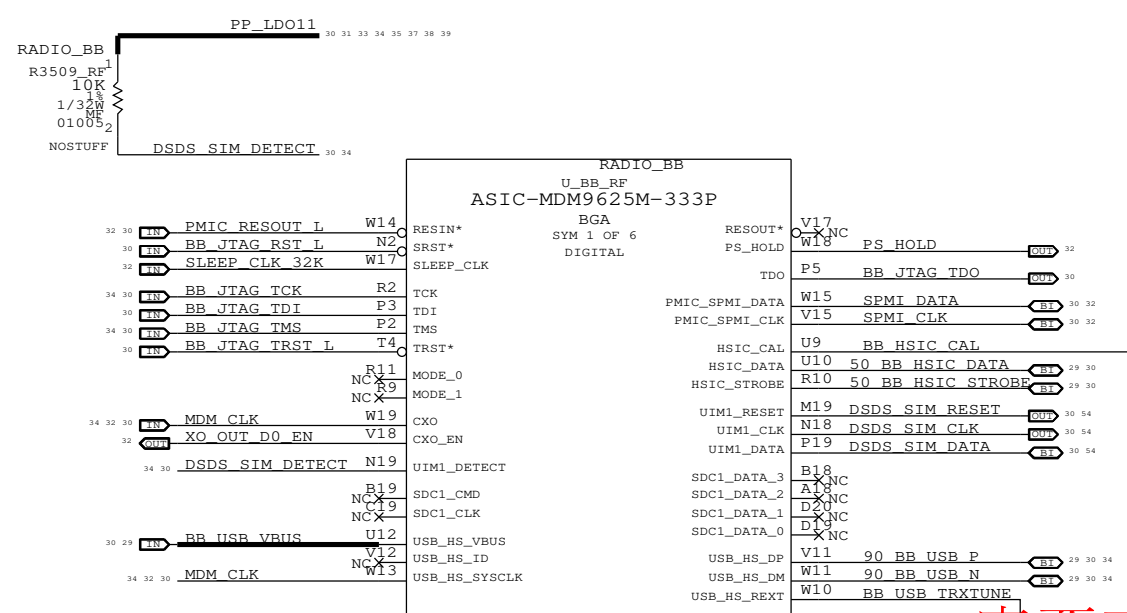
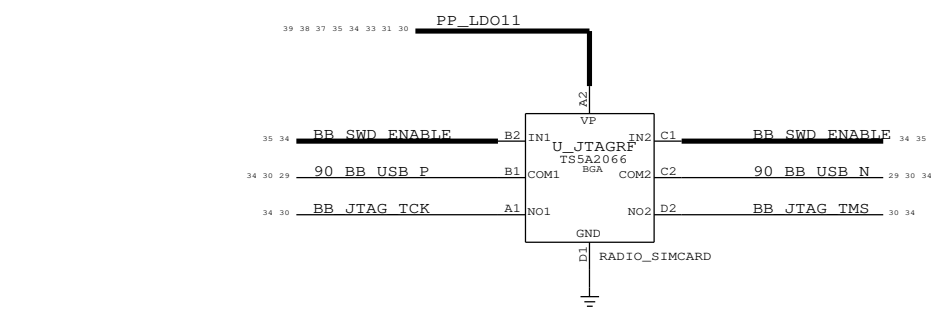

广西南宁功夫手机维修培训
 修一切苹果 招天下学生
 十年一线维修经验及教学经验

让学员们快速学会维修技术及原理分析
 详情请加：
 QQ：343974077 翁老师电话：13737083768
 QQ：344106191 王老师电话：13737070888

PAGE TITLE	
BASEBAND (1 OF 2)	
Apple Inc.	DRAWING NUMBER: 051-9903 D
	REVISION: 7.0.0
NOTICE OF PROPRIETARY PROPERTY:	BRANCH:
THE INFORMATION CONTAINED HEREIN IS THE PROPRIETARY PROPERTY OF APPLE, INC. THE POSSESSOR AGREES TO THE FOLLOWING:	PAGE: 35 OF 55
I TO MAINTAIN THIS DOCUMENT IN CONFIDENCE	SHEET: 34 OF 54
II NOT TO REPRODUCE OR COPY IT	
III NOT TO REVEAL OR PUBLISH IT IN WHOLE OR PART	
IV ALL RIGHTS RESERVED	

1
C704
R700
L700
U702

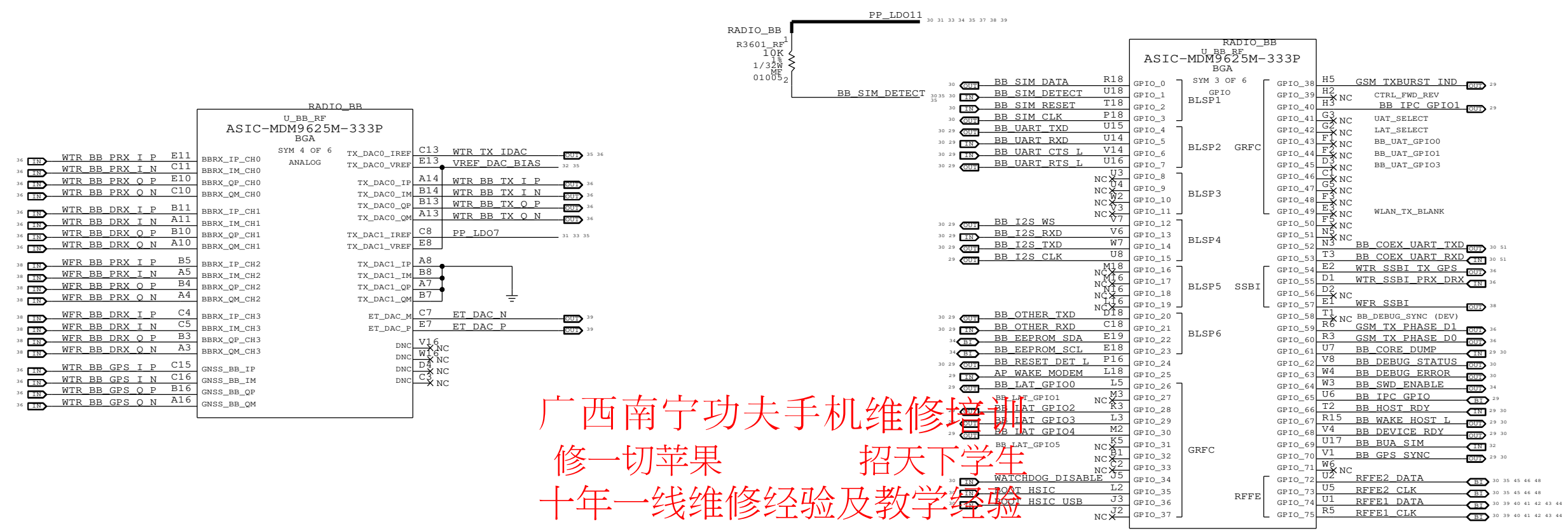

广西南宁功夫手机维修培训
修一切苹果 招天下学生
十年一线维修经验及教学经验

让学员们快速学会维修技术及原理分析
详情请加：
QQ：343974077 翁老师电话：13737083768
QQ：344106191 王老师电话：13737070888

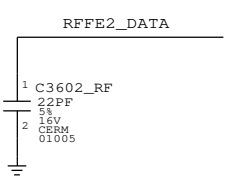
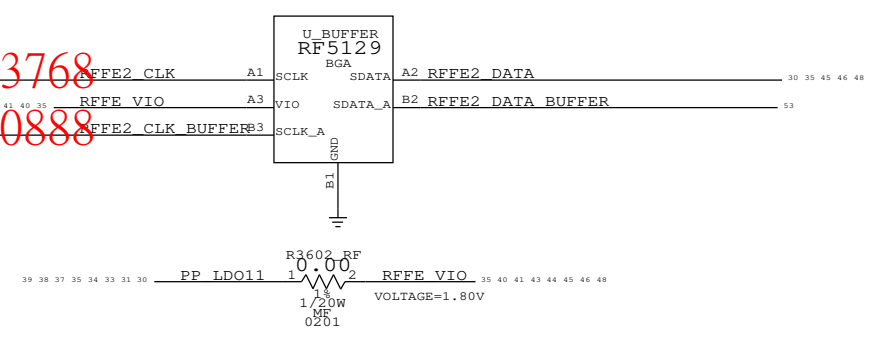
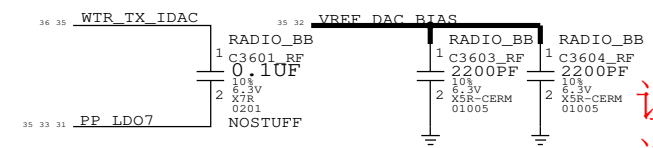

MOBILE DATA MODEM (2 OF 2)	
Apple Inc.	DRAWING NUMBER: 051-9903 D
	REVISION: 7.0.0
NOTICE OF PROPRIETARY PROPERTY:	BRANCH:
THE INFORMATION CONTAINED HEREIN IS THE PROPRIETARY PROPERTY OF APPLE INC. THE POSSESSOR AGREES TO THE FOLLOWING:	PAGE: 36 OF 55
I TO MAINTAIN THIS DOCUMENT IN CONFIDENCE	SHEET: 35 OF 54
II NOT TO REPRODUCE OR COPY IT	
III NOT TO REVEAL OR PUBLISH IT IN WHOLE OR PART	
IV ALL RIGHTS RESERVED	

WTR TRANSCEIVER (1 OF 2)

CONFIDENTIAL AND PROPRIETARY APPLE SYSTEM DESIGN. FOR REFERENCE PURPOSES ONLY - NOT A CHANGE REQUEST.

8
1
C802
R802
L800
U803

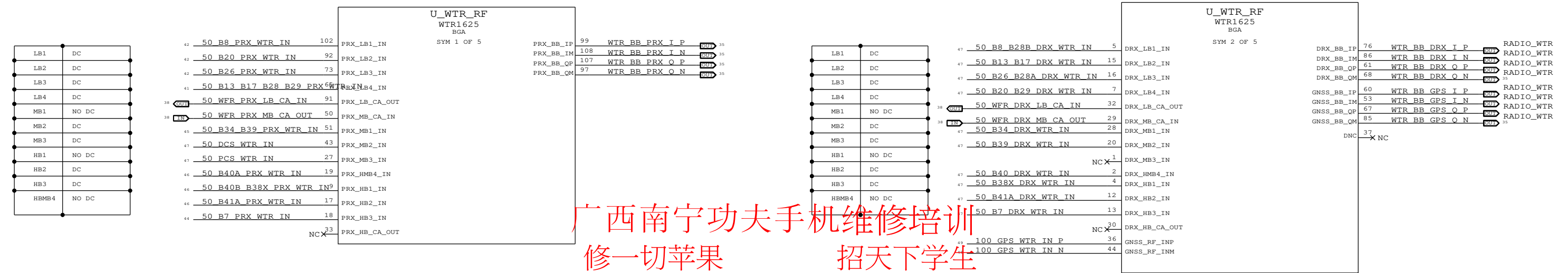

广西南宁功夫手机维修培训
 修一切苹果 招天下学生
 十年一线维修经验及教学经验

让学员们快速学会维修技术及原理分析

详情请加:
 QQ: 343974077 翁老师电话: 13737083768
 QQ: 344106191 王老师电话: 13737070888

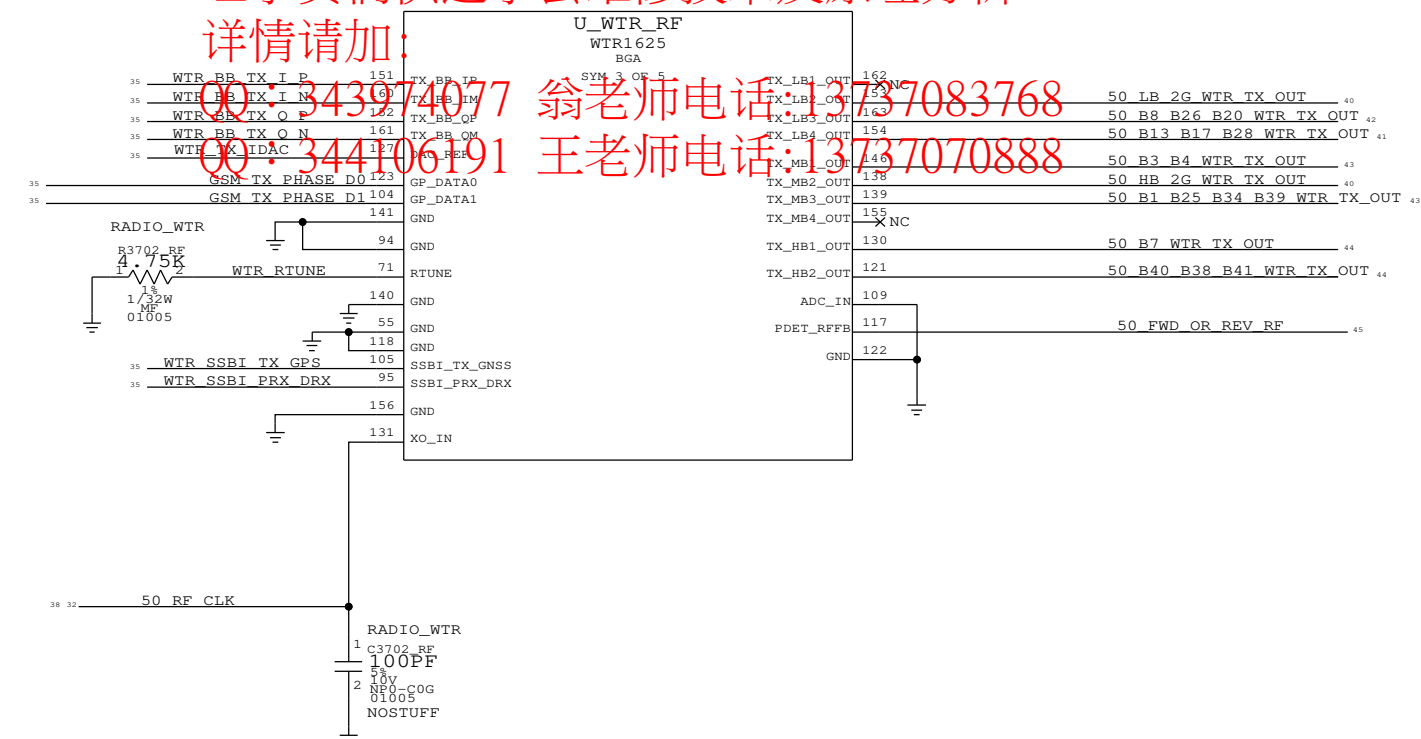

RF_CLK IS SHARED BETWEEN WTR AND WFR. LENGTH DIFFERENCE BETWEEN THE TWO SHOULD BE < 5MM.

RF TRANSCEIVER (1 OF 3)

Apple Inc.	DRAWING NUMBER: 051-9903 D	SIZE
	REVISION: 7.0.0	
NOTICE OF PROPRIETARY PROPERTY:		BRANCH
THE INFORMATION CONTAINED HEREIN IS THE PROPRIETARY PROPERTY OF APPLE, INC. THE POSSESSOR AGREES TO THE FOLLOWING:		PAGE: 37 OF 55
I TO MAINTAIN THIS DOCUMENT IN CONFIDENCE		SHEET: 36 OF 54
II NOT TO REPRODUCE OR COPY IT		
III NOT TO REVEAL OR PUBLISH IT IN WHOLE OR PART		
IV ALL RIGHTS RESERVED		

WTR TRANSCIEVER (2 OF 2)

C934
R926
L3802_RF
U902

WTR DECOUPLING CAPS

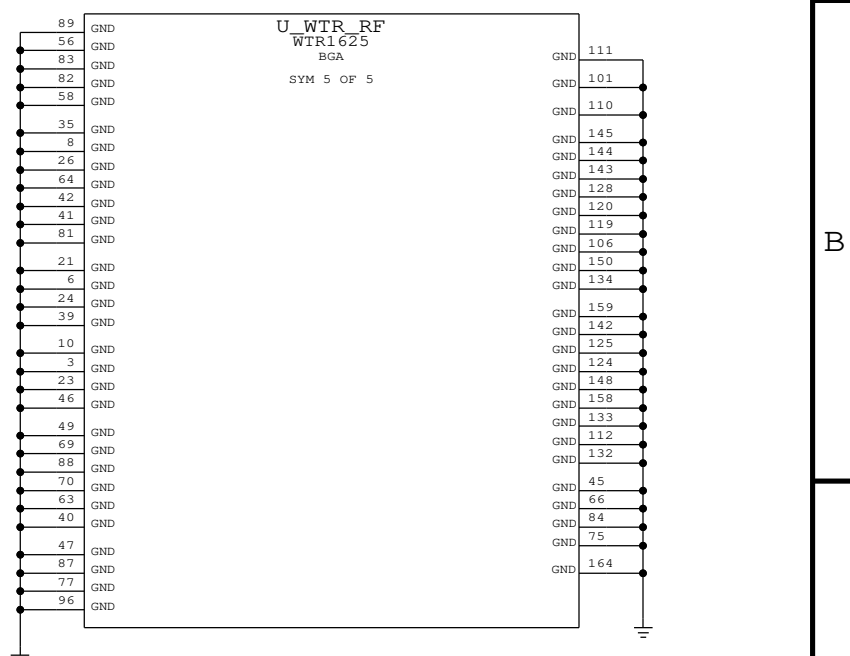
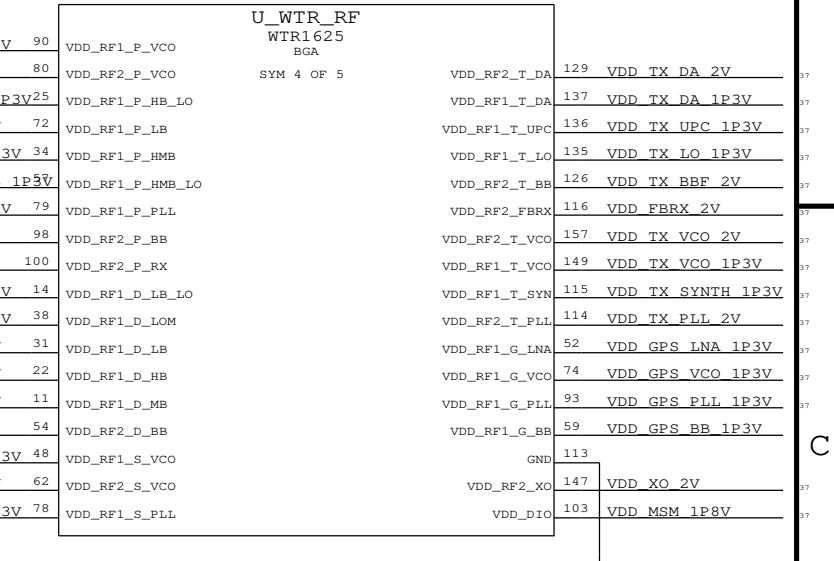
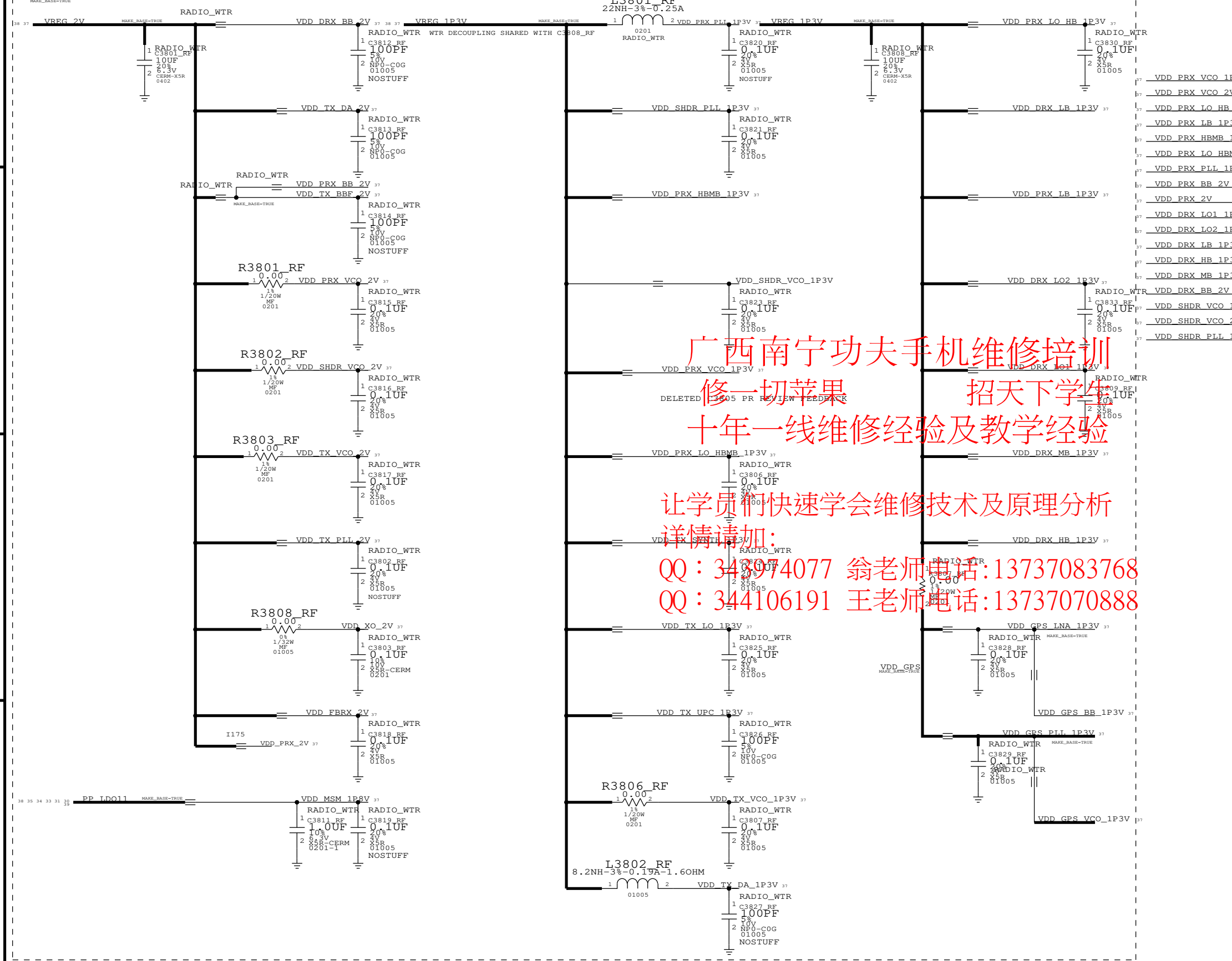

广西南宁功夫手机维修培训
修一切苹果 招天下学生
十年一线维修经验及教学经验
让学员们快速学会维修技术及原理分析
详情请加:
QQ: 344074077 翁老师 电话: 13737083768
QQ: 344106191 王老师 电话: 13737070888

WFR TRANSCIEVER

CONFIDENTIAL AND PROPRIETARY APPLE SYSTEM DESIGN. FOR REFERENCE PURPOSES ONLY - NOT A CHANGE REQUEST.

C1019
R1016
L1000
U1002

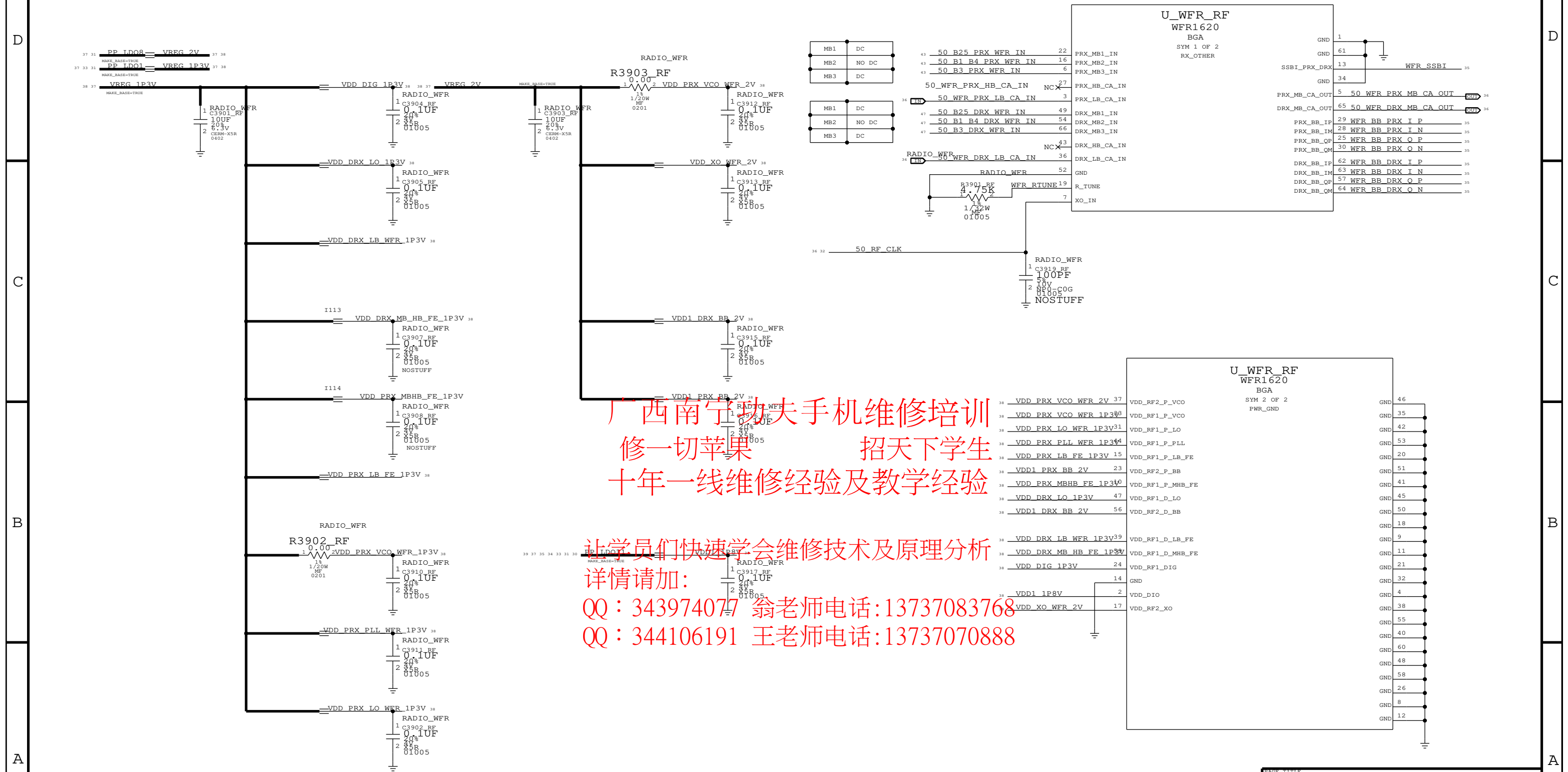

广西南宁功夫手机维修培训
修一切苹果 招天下学生
十年一线维修经验及教学经验

让学员们快速学会维修技术及原理分析
详情请加：
QQ：343974077 翁老师电话：13737083768
QQ：344106191 王老师电话：13737070888

RF TRANSCIEVER (3 OF 3)

Apple Inc.	DRAWING NUMBER 051-9903 D
NOTICE OF PROPRIETARY PROPERTY: THE INFORMATION CONTAINED HEREIN IS THE PROPRIETARY PROPERTY OF APPLE, INC. THE POSSESSOR AGREES TO THE FOLLOWING: I TO MAINTAIN THIS DOCUMENT IN CONFIDENCE II NOT TO REPRODUCE OR COPY IT III NOT TO REVEAL OR PUBLISH IT IN WHOLE OR PART IV ALL RIGHTS RESERVED	REVISION 7.0.0
	PAGE 39 OF 55
	SHEET 38 OF 54

1
C1110
R1102
L1104
U1101

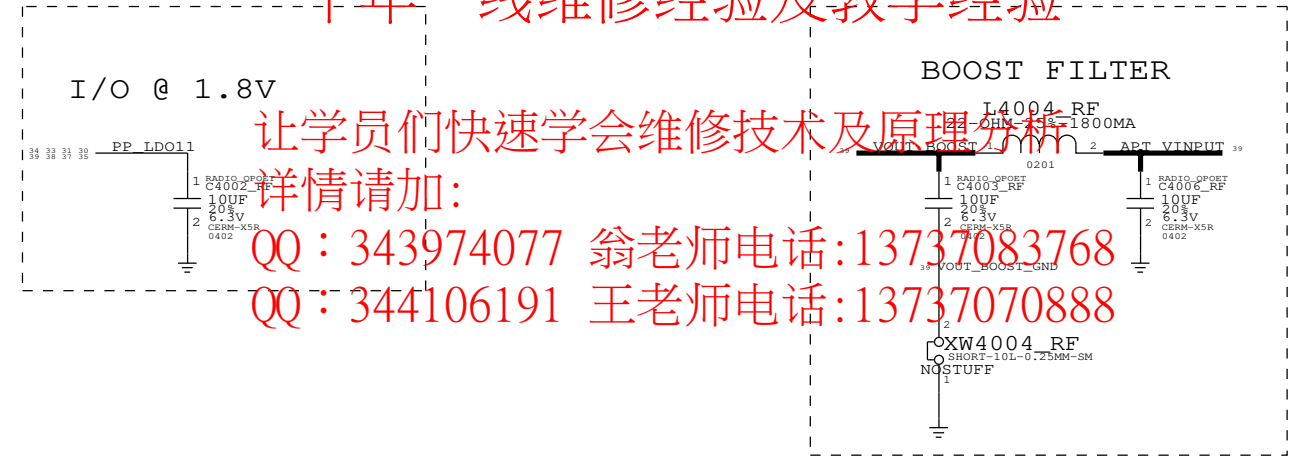
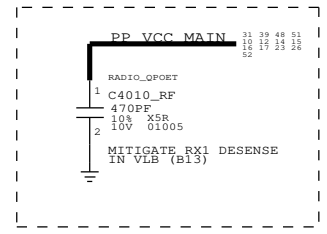
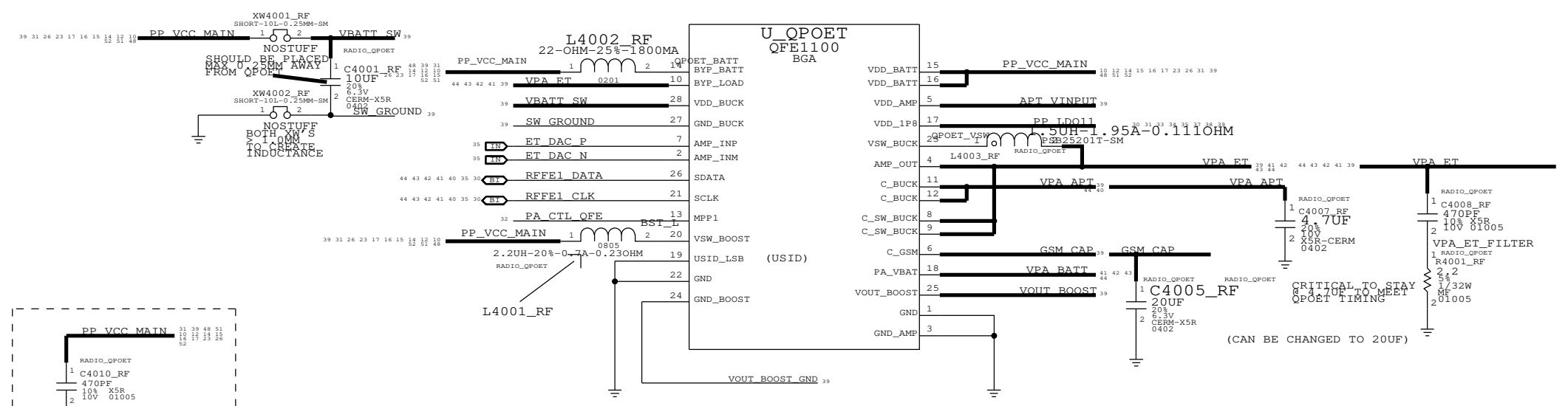

广西南宁功夫手机维修培训
 修一切苹果 招天下学生
 十年一线维修经验及教学经验

让学员们快速学会维修技术及原理分析
 详情请加:
 QQ: 343974077 翁老师电话: 13737083768
 QQ: 344106191 王老师电话: 13737070888

PAGE TITLE		
QFE DCDC		
DRAWING NUMBER		SIZE
051-9903		D
REVISION		
7.0.0		
NOTICE OF PROPRIETARY PROPERTY:		
THE INFORMATION CONTAINED HEREIN IS THE PROPRIETARY PROPERTY OF APPLE INC. THE POSSESSOR AGREES TO THE FOLLOWING:		
I TO MAINTAIN THIS DOCUMENT IN CONFIDENCE		
II NOT TO REPRODUCE OR COPY IT		
III NOT TO REVEAL OR PUBLISH IT IN WHOLE OR PART		
IV ALL RIGHTS RESERVED		
PAGE		
40 OF 55		
SHEET		
39 OF 54		

2G PA

<https://www.mobile-manuals.com/>

CONFIDENTIAL AND PROPRIETARY APPLE SYSTEM DESIGN. FOR REFERENCE PURPOSES ONLY - NOT A CHANGE REQUEST.

C1208
R1200
L1204
U1201

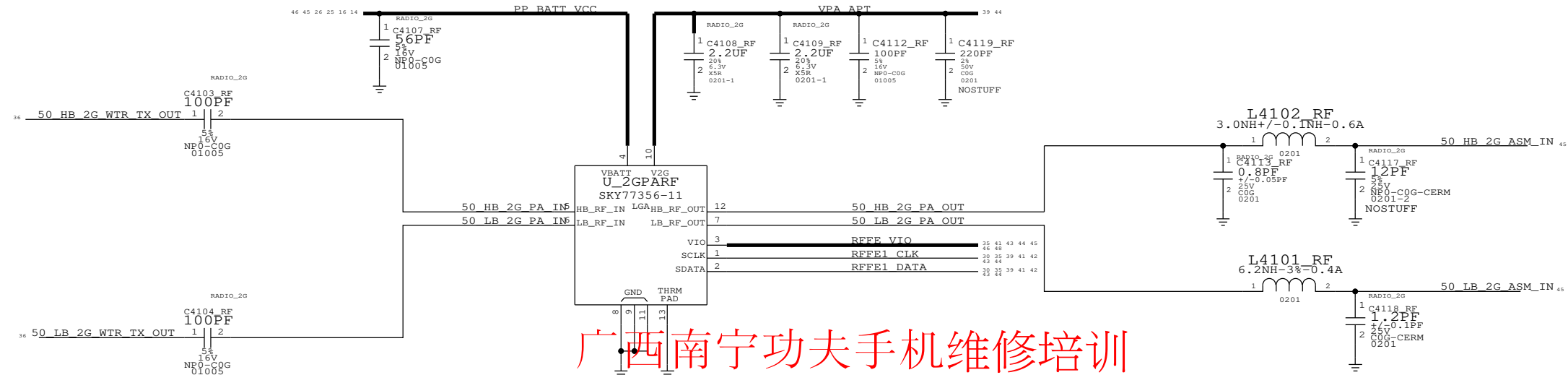

广西南宁功夫手机维修培训
修一切苹果 招天下学生
十年一线维修经验及教学经验

让学员们快速学会维修技术及原理分析
详情请加:

QQ: 343974077 翁老师电话: 13737083768

QQ: 344106191 王老师电话: 13737070888

PAGE TITLE		2G PA	
Apple Inc.	DRAWING NUMBER	051-9903	SIZE
	REVISION	7.0.0	
NOTICE OF PROPRIETARY PROPERTY:		BRANCH	
THE INFORMATION CONTAINED HEREIN IS THE PROPRIETARY PROPERTY OF APPLE, INC. THE POSSESSOR AGREES TO THE FOLLOWING:		PAGE	
I TO MAINTAIN THIS DOCUMENT IN CONFIDENCE		41 OF 55	
II NOT TO REPRODUCE OR COPY IT		SHEET	
III NOT TO REVEAL OR PUBLISH IT IN WHOLE OR PART		40 OF 54	
IV ALL RIGHTS RESERVED			

VERY LOW BAND PAD (B13, B17, B28)

CONFIDENTIAL AND PROPRIETARY APPLE SYSTEM DESIGN. FOR REFERENCE PURPOSES ONLY - NOT A CHANGE REQUEST.

1
C1332
R1300
L4215_RF
U1304

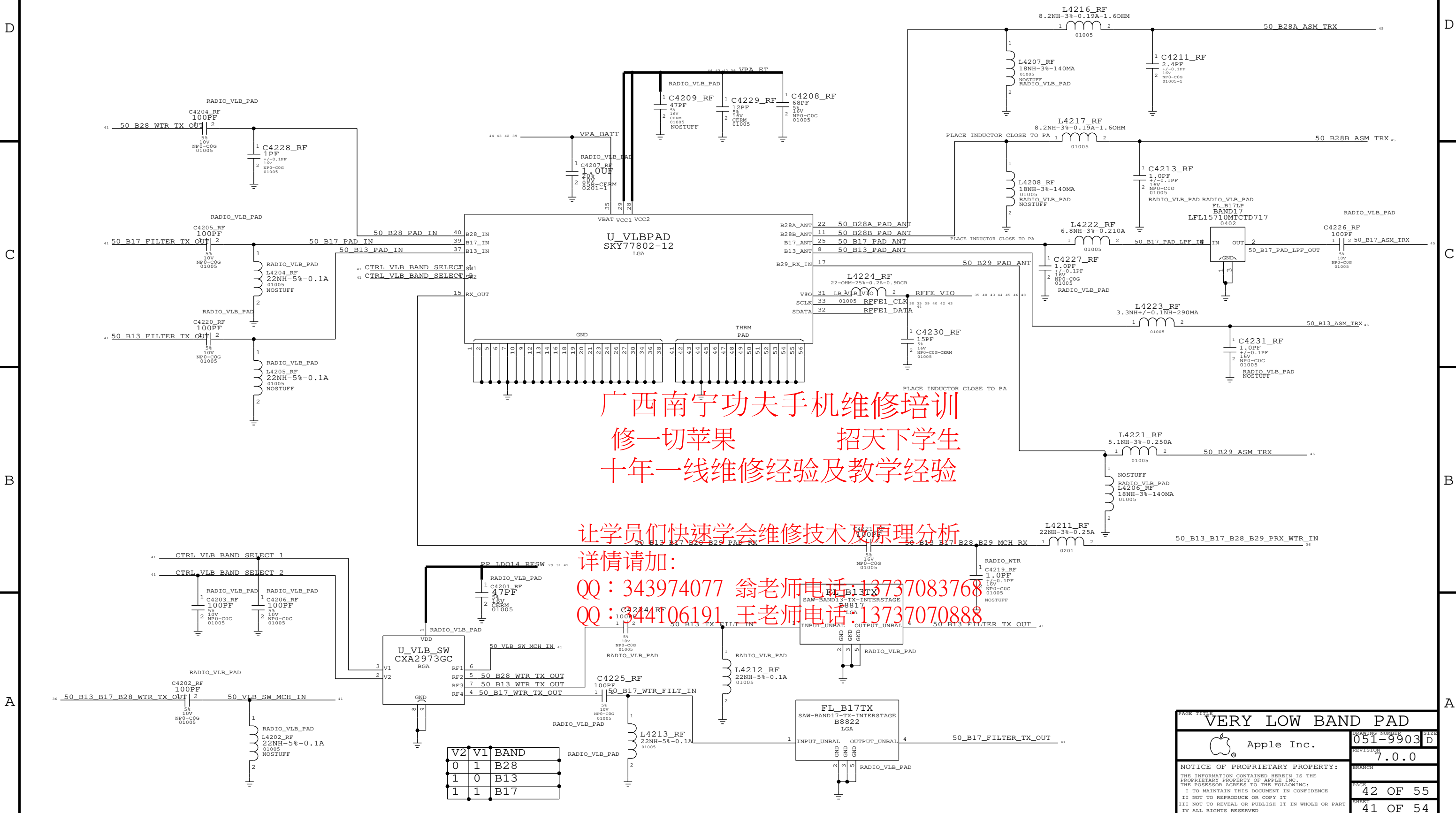

广西南宁功夫手机维修培训
修一切苹果 招天下学生
十年一线维修经验及教学经验

让学员们快速学会维修技术及原理分析
详情请加：
QQ：343974077 翁老师电话：13737083768
QQ：344106191 王老师电话：13737070888

V2	V1	BAND
0	1	B28
1	0	B13
1	1	B17

DRAWING NUMBER		051-9903 D
REVISION		7.0.0
PAGE		42 OF 55
SHEET		41 OF 54

Apple Inc.
NOTICE OF PROPRIETARY PROPERTY:
THE INFORMATION CONTAINED HEREIN IS THE PROPRIETARY PROPERTY OF APPLE INC. THE POSSESSOR AGREES TO THE FOLLOWING:
I TO MAINTAIN THIS DOCUMENT IN CONFIDENCE
II NOT TO REPRODUCE OR COPY IT
III NOT TO REVEAL OR PUBLISH IT IN WHOLE OR PART
IV ALL RIGHTS RESERVED

LOW BAND PAD (B8, B26, B20)

CONFIDENTIAL AND PROPRIETARY APPLE SYSTEM DESIGN. FOR REFERENCE PURPOSES ONLY - NOT A CHANGE REQUEST.

1
C4318_RF
R1400
L4322_RF
U1402

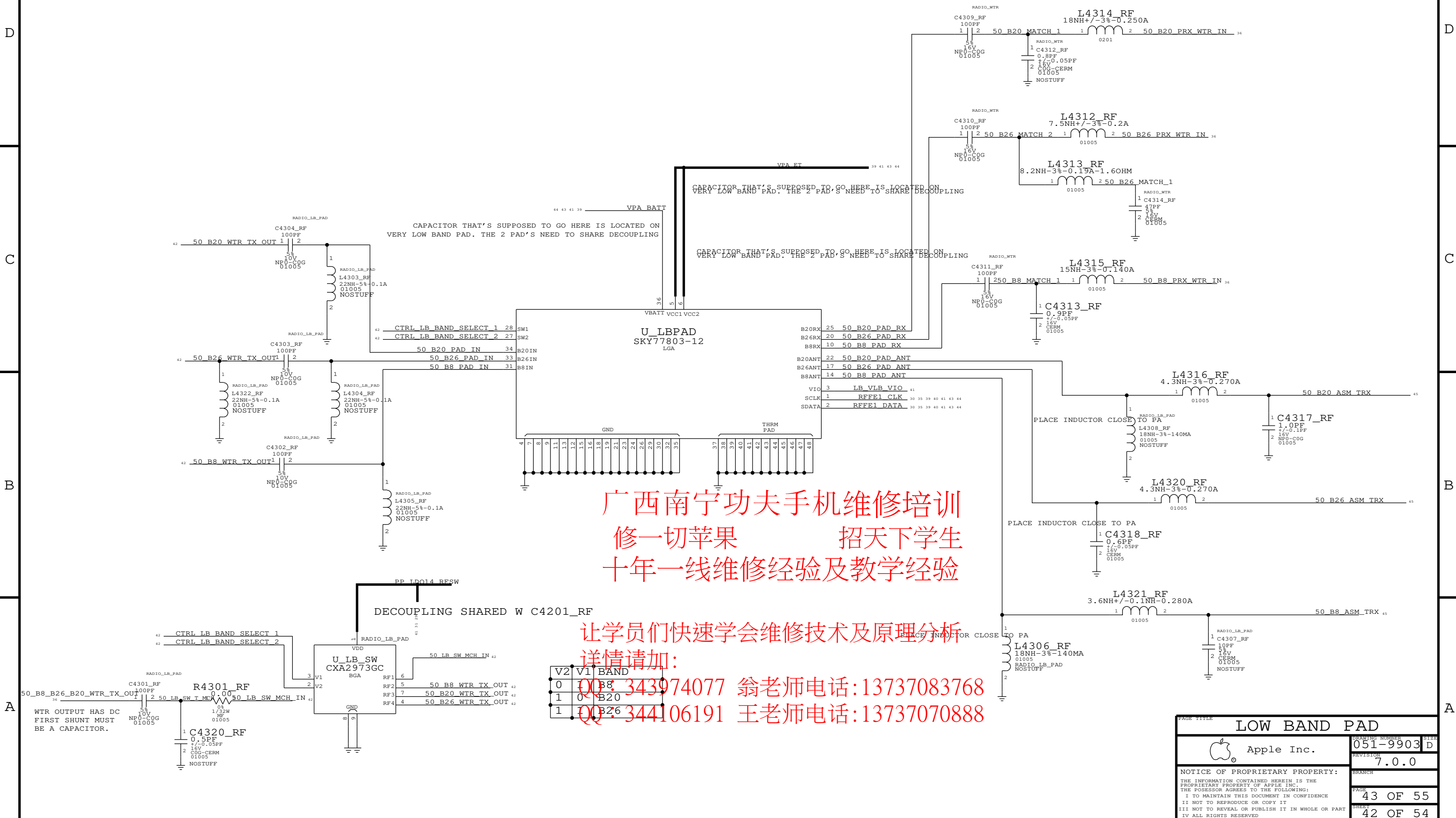

广西南宁功夫手机维修培训
修一切苹果 招天下学生
十年一线维修经验及教学经验

让学员们快速学会维修技术及原理分析
详情请加：
QQ: 343974077 翁老师电话: 13737083768
QQ: 344106191 王老师电话: 13737070888

V2	V1	BAND
0	0	B8
1	0	B20
1	1	B26

PAGE TITLE	
LOW BAND PAD	
Apple Inc.	
DRAWING NUMBER	051-9903 D
REVISION	7.0.0
NOTICE OF PROPRIETARY PROPERTY: THE INFORMATION CONTAINED HEREIN IS THE PROPRIETARY PROPERTY OF APPLE INC. THE POSSESSOR AGREES TO THE FOLLOWING: I TO MAINTAIN THIS DOCUMENT IN CONFIDENCE II NOT TO REPRODUCE OR COPY IT III NOT TO REVEAL OR PUBLISH IT IN WHOLE OR PART IV ALL RIGHTS RESERVED	
BRANCH	
PAGE	43 OF 55
SHEET	42 OF 54

MID BAND PAD (B1, B25, B3, B4, B34, B39)

CONFIDENTIAL AND PROPRIETARY APPLE SYSTEM DESIGN. FOR REFERENCE PURPOSES ONLY - NOT A CHANGE REQUEST.

1
C4426_RF
R1500
L4409_RF
U1501

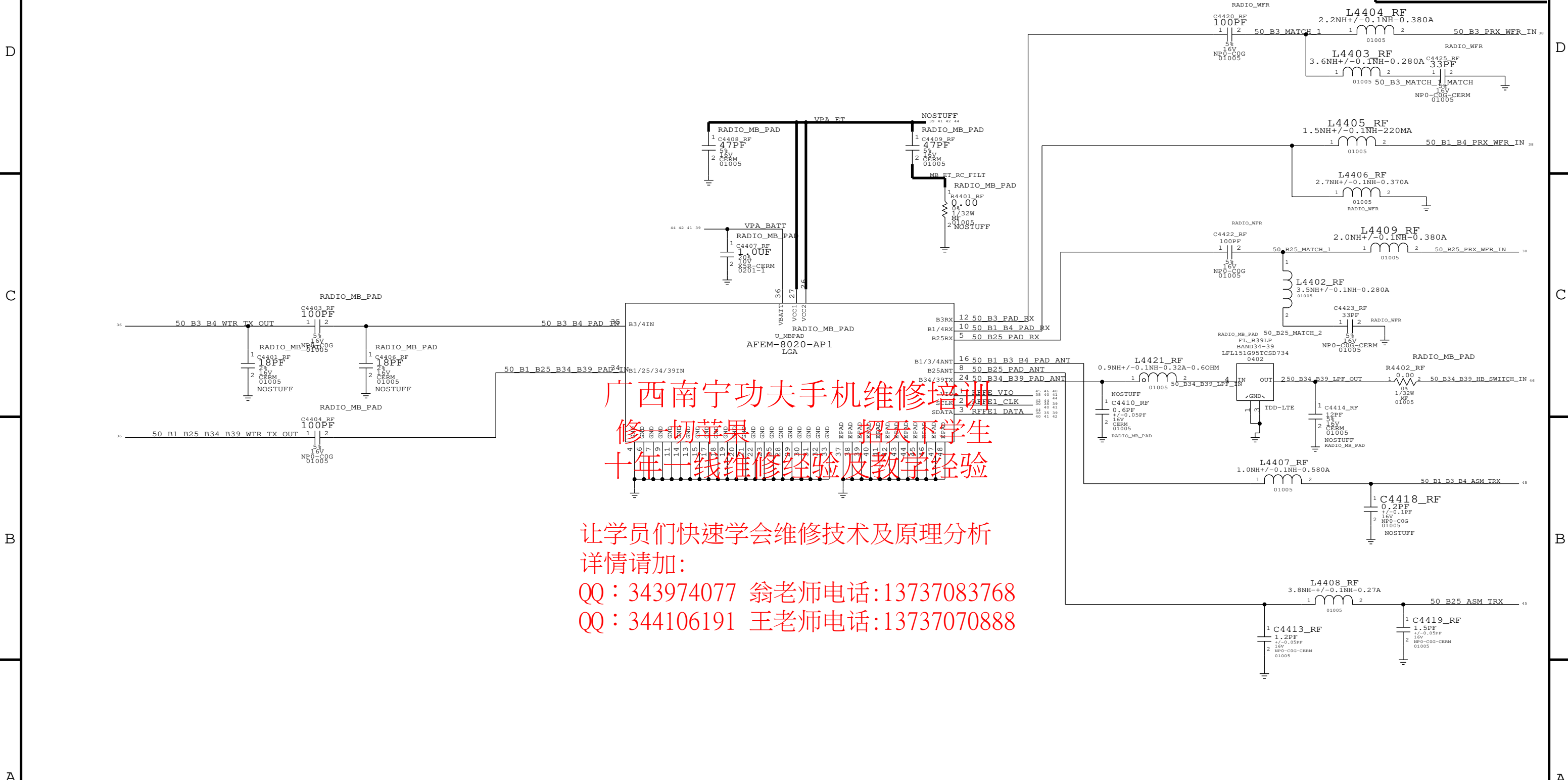

广西南宁功夫手机维修培训
修一切苹果手机
十年一线维修经验及教学经验

让学员们快速学会维修技术及原理分析
详情请加：
QQ：343974077 翁老师电话：13737083768
QQ：344106191 王老师电话：13737070888

PAGE TITLE		
MID BAND PAD		
Apple Inc.		DRAWING NUMBER
		051-9903 D
		REVISION
		7.0.0
NOTICE OF PROPRIETARY PROPERTY:		BRANCH
THE INFORMATION CONTAINED HEREIN IS THE PROPRIETARY PROPERTY OF APPLE, INC. THE POSSESSOR AGREES TO THE FOLLOWING:		PAGE
I TO MAINTAIN THIS DOCUMENT IN CONFIDENCE		44 OF 55
II NOT TO REPRODUCE OR COPY IT		SHEET
III NOT TO REVEAL OR PUBLISH IT IN WHOLE OR PART		43 OF 54
IV ALL RIGHTS RESERVED		

HIGH BAND PAD (B7, B38, B40, B41, XGP)

CONFIDENTIAL AND PROPRIETARY APPLE SYSTEM DESIGN. FOR REFERENCE PURPOSES ONLY - NOT A CHANGE REQUEST.

1
C4533_RF
R1600
L1616
U1601

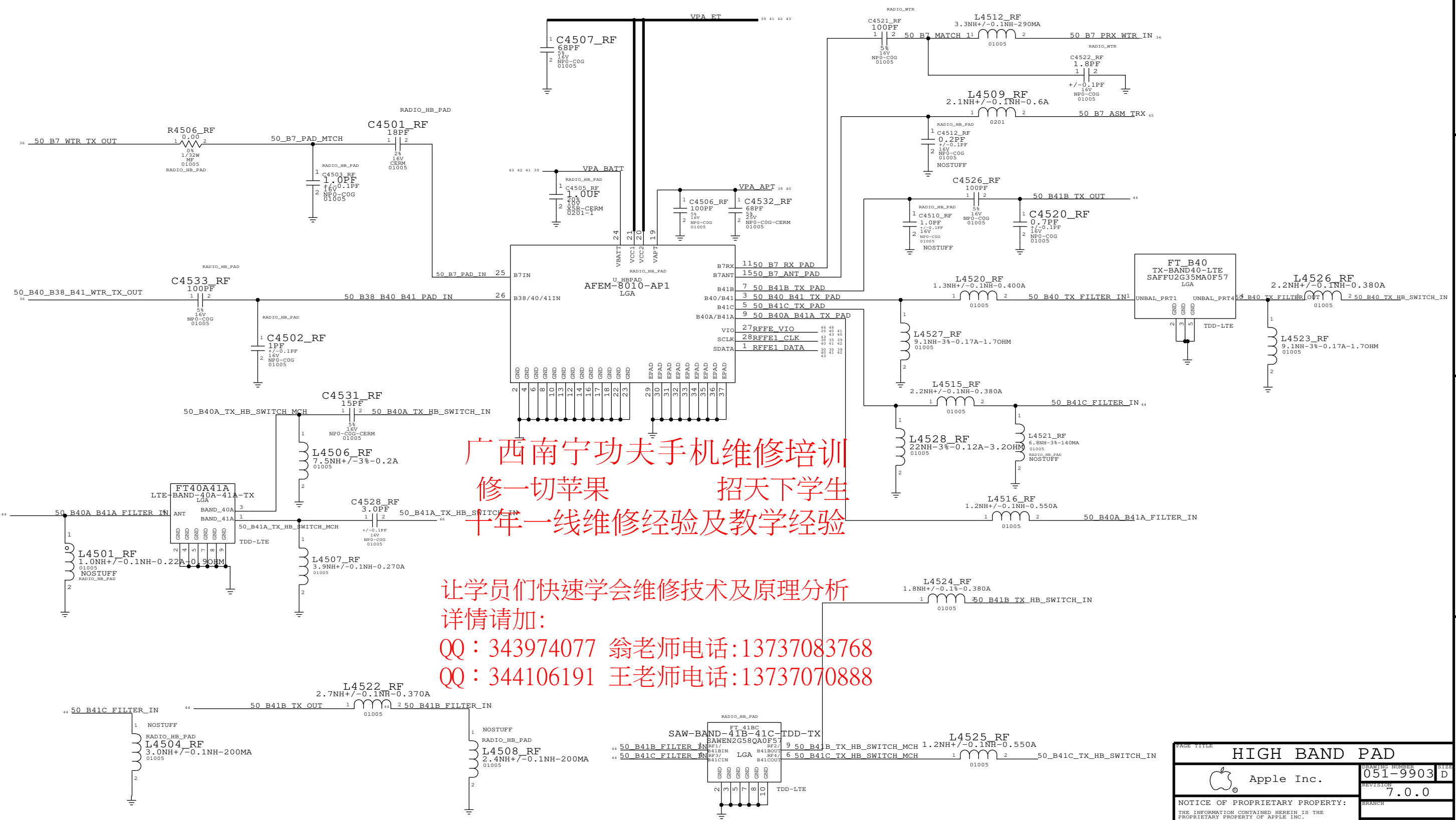

广西南宁功夫手机维修培训
修一切苹果 招天下学生
十年一线维修经验及教学经验

让学员们快速学会维修技术及原理分析
详情请加：
QQ：343974077 翁老师电话：13737083768
QQ：344106191 王老师电话：13737070888

DRAWING TITLE		
HIGH BAND PAD		
Apple Inc.		DRAWING NUMBER
		051-9903
		REVISION
		7.0.0
NOTICE OF PROPRIETARY PROPERTY:		BRANCH
THE INFORMATION CONTAINED HEREIN IS THE PROPRIETARY PROPERTY OF APPLE, INC. THE POSSESSOR AGREES TO THE FOLLOWING:		PAGE
I TO MAINTAIN THIS DOCUMENT IN CONFIDENCE		45 OF 55
II NOT TO REPRODUCE OR COPY IT		SHEET
III NOT TO REVEAL OR PUBLISH IT IN WHOLE OR PART		44 OF 54
IV ALL RIGHTS RESERVED		

ANTENNA SWITCH

CONFIDENTIAL AND PROPRIETARY APPLE SYSTEM DESIGN. FOR REFERENCE PURPOSES ONLY - NOT A CHANGE REQUEST.

1
C1702
R1700
L4608_RF
U1702

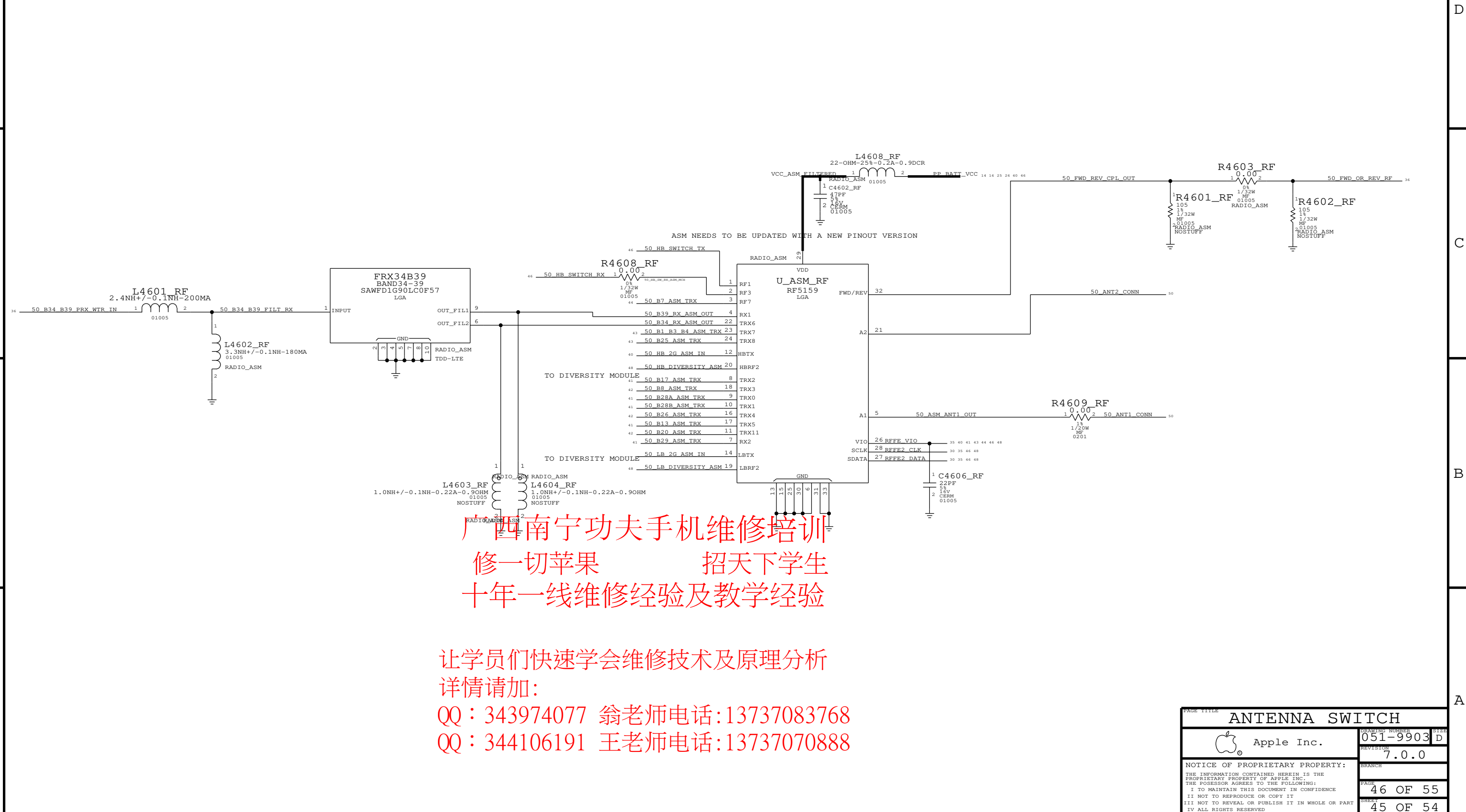

广西南宁功夫手机维修培训
修一切苹果 招天下学生
十年一线维修经验及教学经验

让学员们快速学会维修技术及原理分析
详情请加：
QQ：343974077 翁老师电话：13737083768
QQ：344106191 王老师电话：13737070888

PAGE TITLE		ANTENNA SWITCH	
DRAWING NUMBER		051-9903	SIZE D
REVISION		7.0.0	
NOTICE OF PROPRIETARY PROPERTY:		BRANCH	
THE INFORMATION CONTAINED HEREIN IS THE PROPRIETARY PROPERTY OF APPLE, INC. THE POSSESSOR AGREES TO THE FOLLOWING:		PAGE	
I TO MAINTAIN THIS DOCUMENT IN CONFIDENCE		46 OF 55	
II NOT TO REPRODUCE OR COPY IT		SHEET	
III NOT TO REVEAL OR PUBLISH IT IN WHOLE OR PART		45 OF 54	
IV ALL RIGHTS RESERVED			

HIGH BAND SWITCH

CONFIDENTIAL AND PROPRIETARY APPLE SYSTEM DESIGN. FOR REFERENCE PURPOSES ONLY - NOT A CHANGE REQUEST.

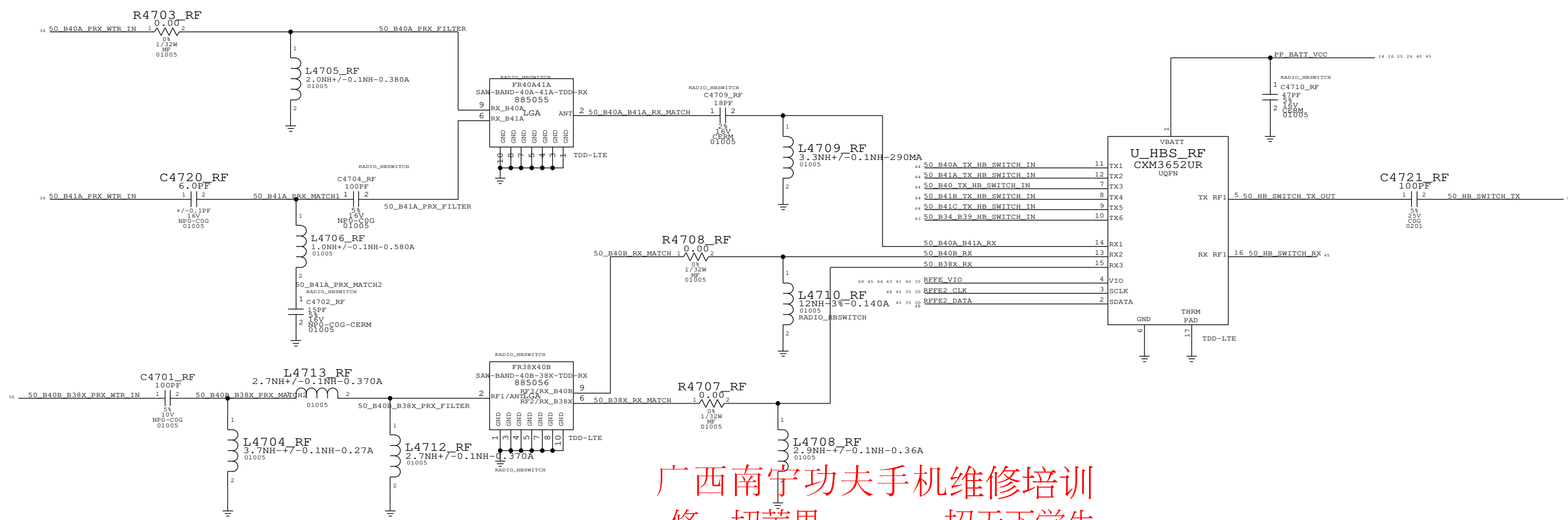

广西南宁功夫手机维修培训
 修一切苹果 招天下学生
 十年一线维修经验及教学经验

让学员们快速学会维修技术及原理分析
 详情请加：
 QQ：343974077 翁老师电话:13737083768
 QQ：344106191 王老师电话:13737070888

PAGE TITLE HIGH BAND SWITCH		
Apple Inc.	DRAWING NUMBER	051-9903
	REVISION	7.0.0
NOTICE OF PROPRIETARY PROPERTY: THE INFORMATION CONTAINED HEREIN IS THE PROPRIETARY PROPERTY OF APPLE, INC. THE POSSESSOR AGREES TO THE FOLLOWING: I TO MAINTAIN THIS DOCUMENT IN CONFIDENCE II NOT TO REPRODUCE OR COPY IT III NOT TO REVEAL OR PUBLISH IT IN WHOLE OR PART IV ALL RIGHTS RESERVED		
BRANCH	PAGE	47 OF 55
SHEET	46 OF 54	

MIDBAND MIDBAND DIVERSITY - WFR

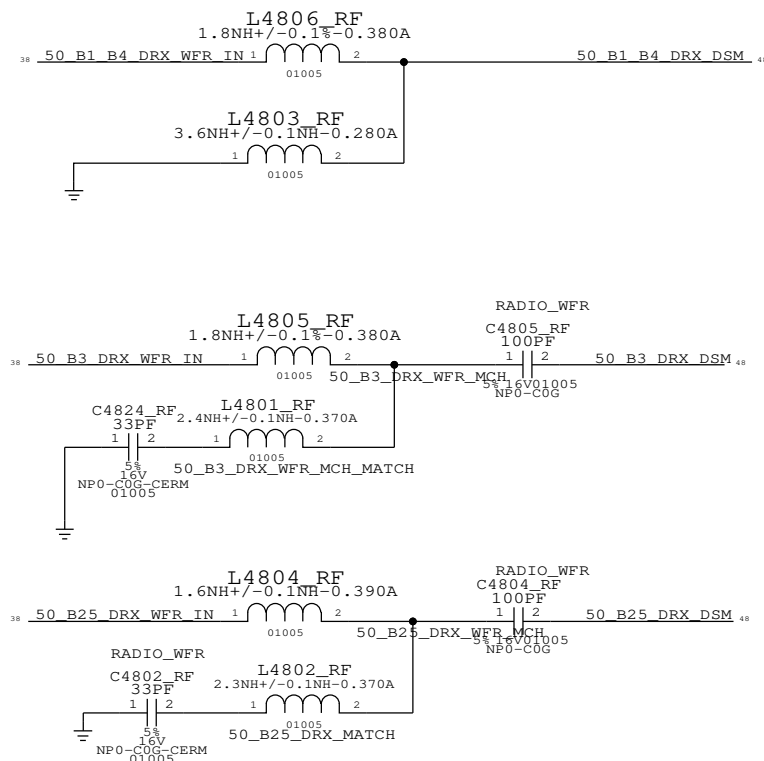

HIGHBAND DIVERSITY - WTR

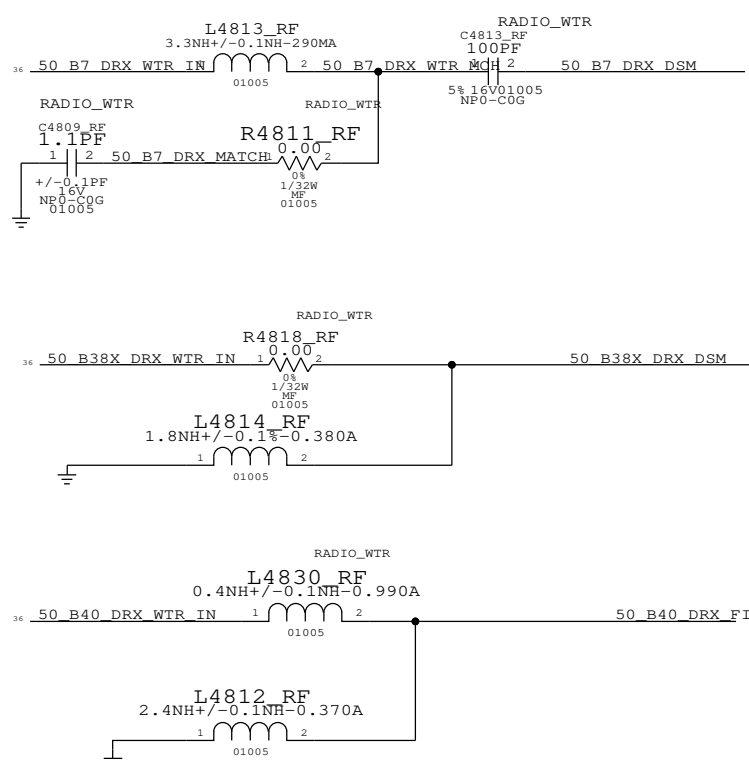

LOWBAND DIVERSITY - WTR

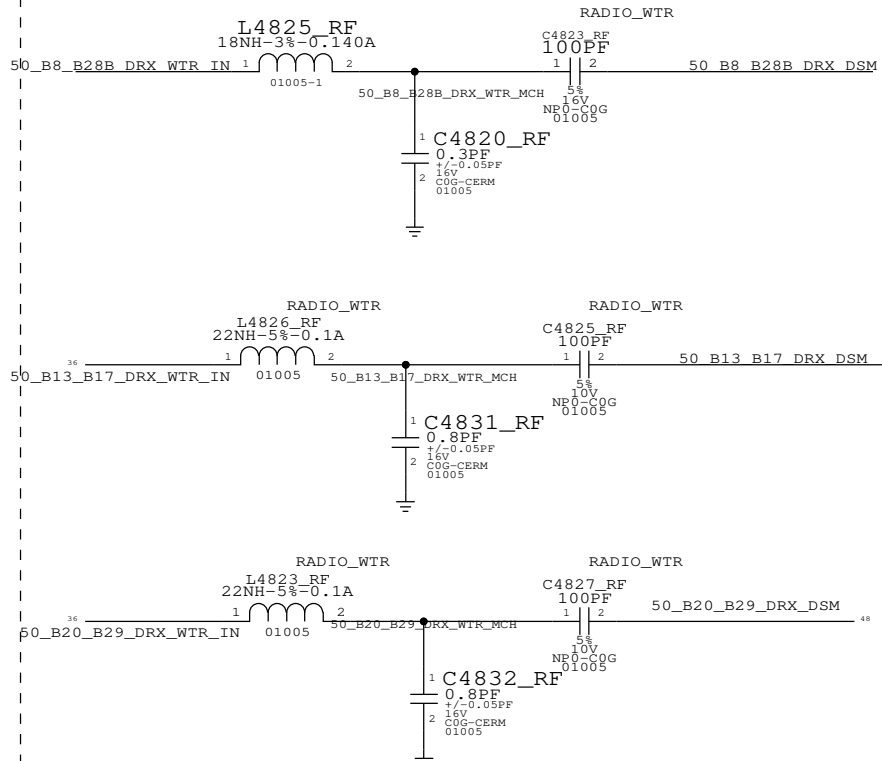

MIDBAND DIVERSITY - WTR

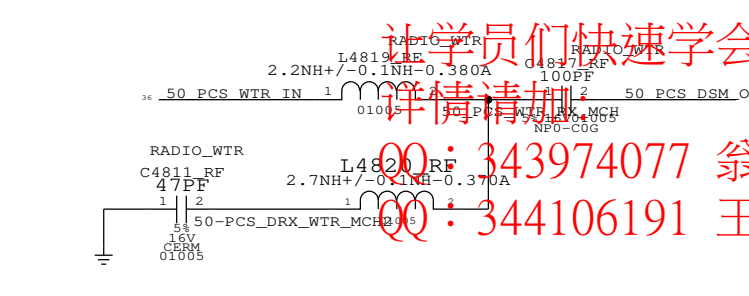
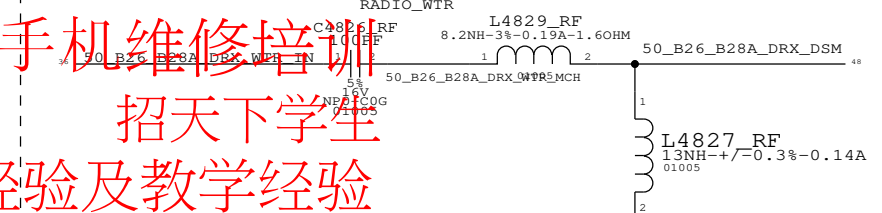
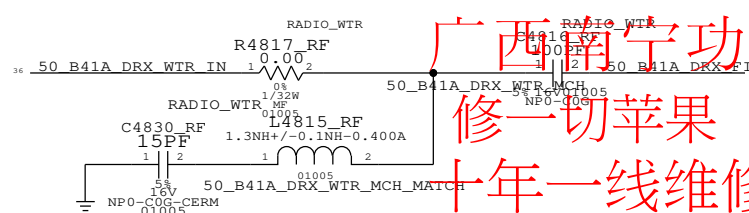
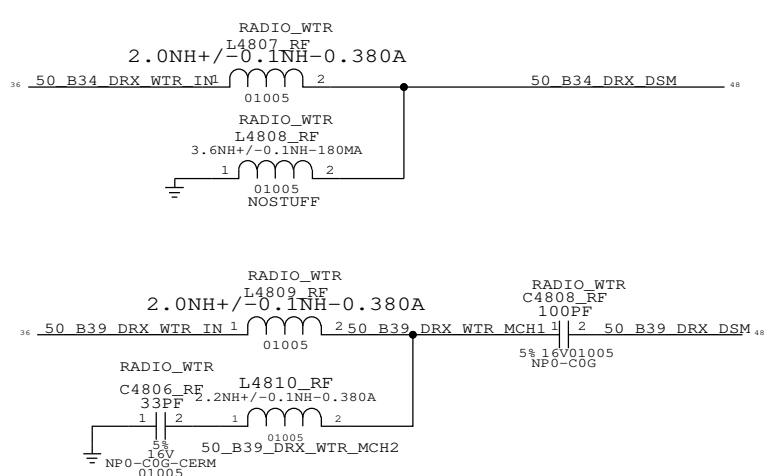

广西南宁功夫手机维修培训
修一切苹果
招天下学生
十年一线维修经验及教学经验

让学员们快速学会维修技术及原理分析
详情请加
QQ: 343974077 翁老师电话: 13737083768
QQ: 344106191 王老师电话: 13737070888

PAGE TITLE		RX DIVERSITY	
DRAWING NUMBER		051-9903	SIZE D
REVISION		7.0.0	
NOTICE OF PROPRIETARY PROPERTY:		THE INFORMATION CONTAINED HEREIN IS THE PROPRIETARY PROPERTY OF APPLE, INC. THE POSSESSOR AGREES TO THE FOLLOWING:	
I TO MAINTAIN THIS DOCUMENT IN CONFIDENCE		BRANCH	
II NOT TO REPRODUCE OR COPY IT		PAGE	48 OF 55
III NOT TO REVEAL OR PUBLISH IT IN WHOLE OR PART		SHEET	47 OF 54
IV ALL RIGHTS RESERVED			

1
C1900
R1900
L1900
U1901

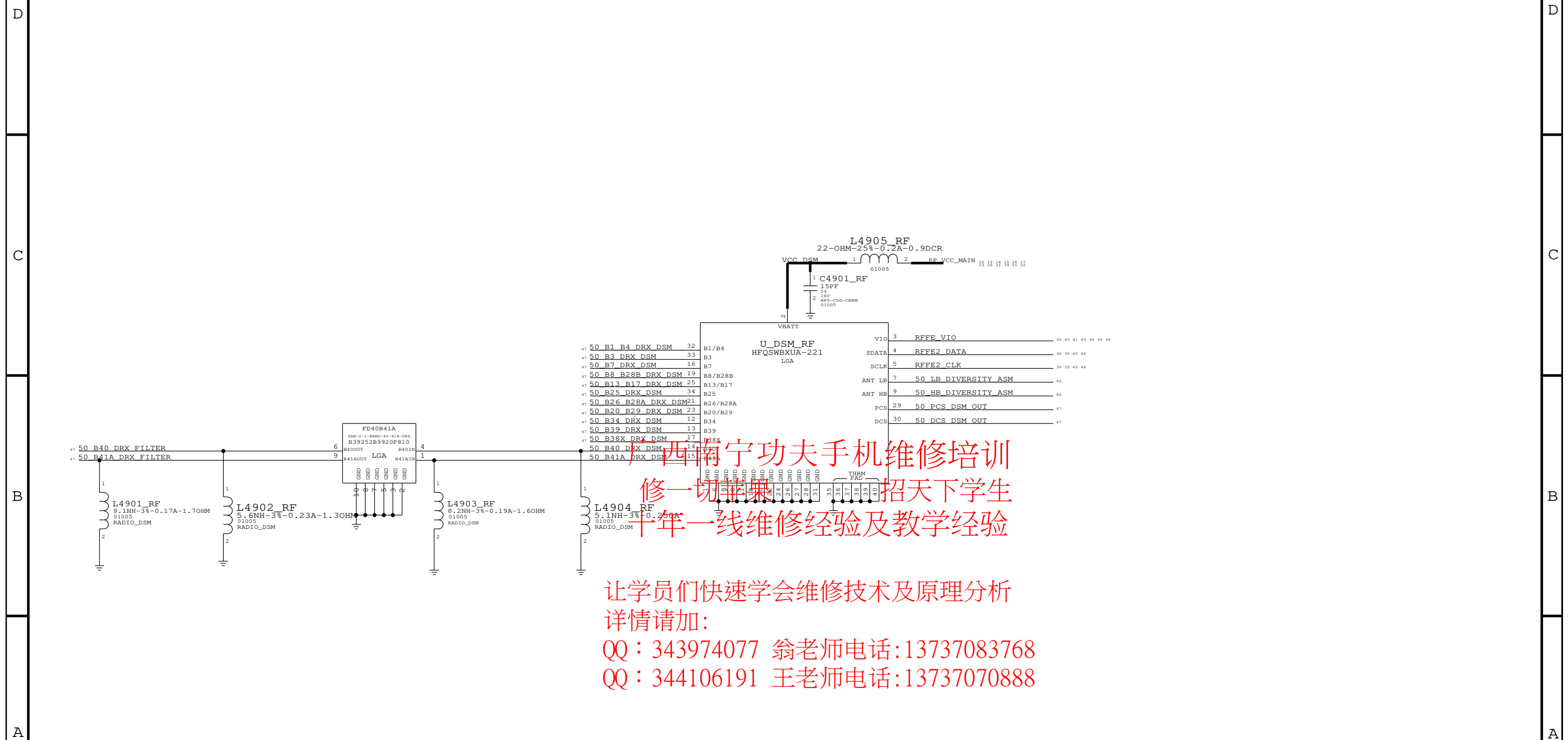

西南宁功夫手机维修培训
 修一切苹果
 十年一线维修经验及教学经验
 招天下学生

让学员们快速学会维修技术及原理分析
 详情请加：
 QQ：343974077 翁老师电话：13737083768
 QQ：344106191 王老师电话：13737070888

PAGE TITLE		GPS	
DRAWING NUMBER		051-9903	SIZE
REVISION		7.0.0	D
NOTICE OF PROPRIETARY PROPERTY:		BRANCH	
THE INFORMATION CONTAINED HEREIN IS THE PROPRIETARY PROPERTY OF APPLE, INC. THE POSSESSOR AGREES TO THE FOLLOWING:		PAGE	
I TO MAINTAIN THIS DOCUMENT IN CONFIDENCE		49 OF 55	
II NOT TO REPRODUCE OR COPY IT		SHEET	
III NOT TO REVEAL OR PUBLISH IT IN WHOLE OR PART		48 OF 54	
IV ALL RIGHTS RESERVED			

广西南宁功夫手机维修培训
修一切苹果 招天下学生
十年一线维修经验及教学经验

让学员们快速学会维修技术及原理分析
详情请加：

QQ：343974077 翁老师电话：13737083768

QQ：344106191 王老师电话：13737070888

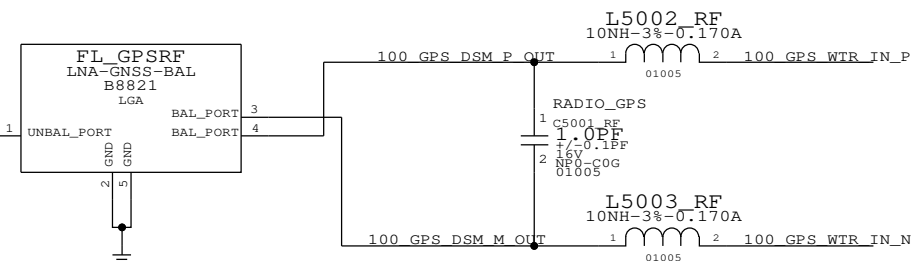

ANTENNA FEEDS

CONFIDENTIAL AND PROPRIETARY APPLE SYSTEM DESIGN. FOR REFERENCE PURPOSES ONLY - NOT A CHANGE REQUEST.

TEST & COAX CONNECTOR FOR LOWER SECTION OF MLB

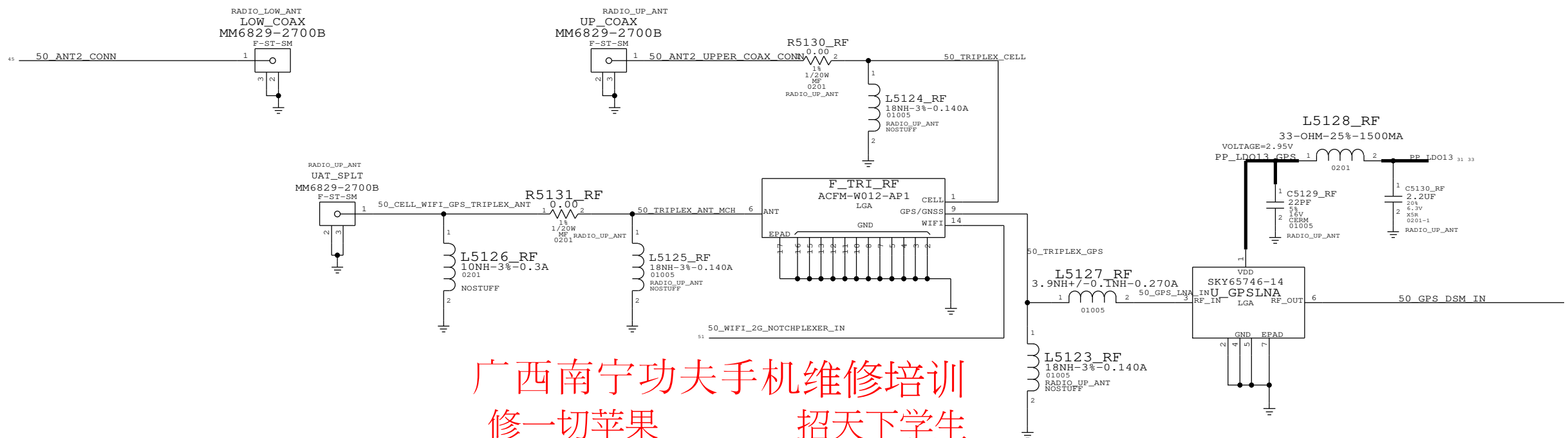

广西南宁功夫手机维修培训
 修一切苹果 招天下学生
 十年一线维修经验及教学经验

让学员们快速学会维修技术及原理分析
 详情请加:

QQ: 343974077 翁老师电话: 13737083768
 QQ: 344106191 王老师电话: 13737070888

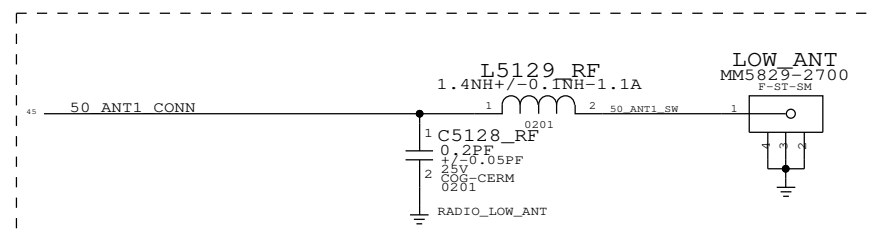
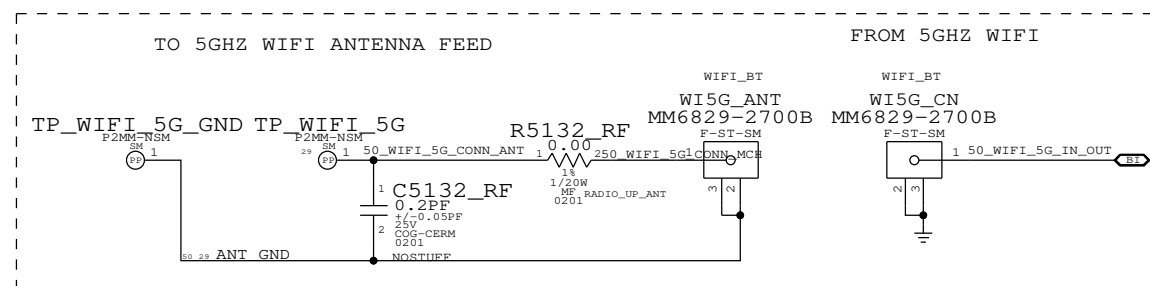
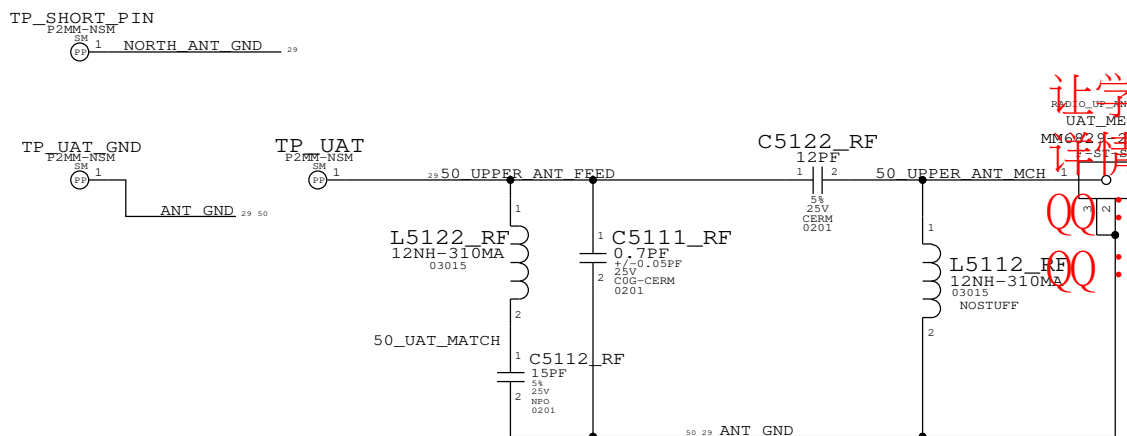

PAGE TITLE		DRAWING NUMBER		SIZE
ANTENNA FEEDS		051-9903		D
Apple Inc.		REVISION		7.0.0
NOTICE OF PROPRIETARY PROPERTY:		BRANCH		
THE INFORMATION CONTAINED HEREIN IS THE PROPRIETARY PROPERTY OF APPLE, INC. THE POSSESSOR AGREES TO THE FOLLOWING:		PAGE		51 OF 55
I TO MAINTAIN THIS DOCUMENT IN CONFIDENCE		SHEET		50 OF 54
II NOT TO REPRODUCE OR COPY IT				
III NOT TO REVEAL OR PUBLISH IT IN WHOLE OR PART				
IV ALL RIGHTS RESERVED				

WLAN/BT

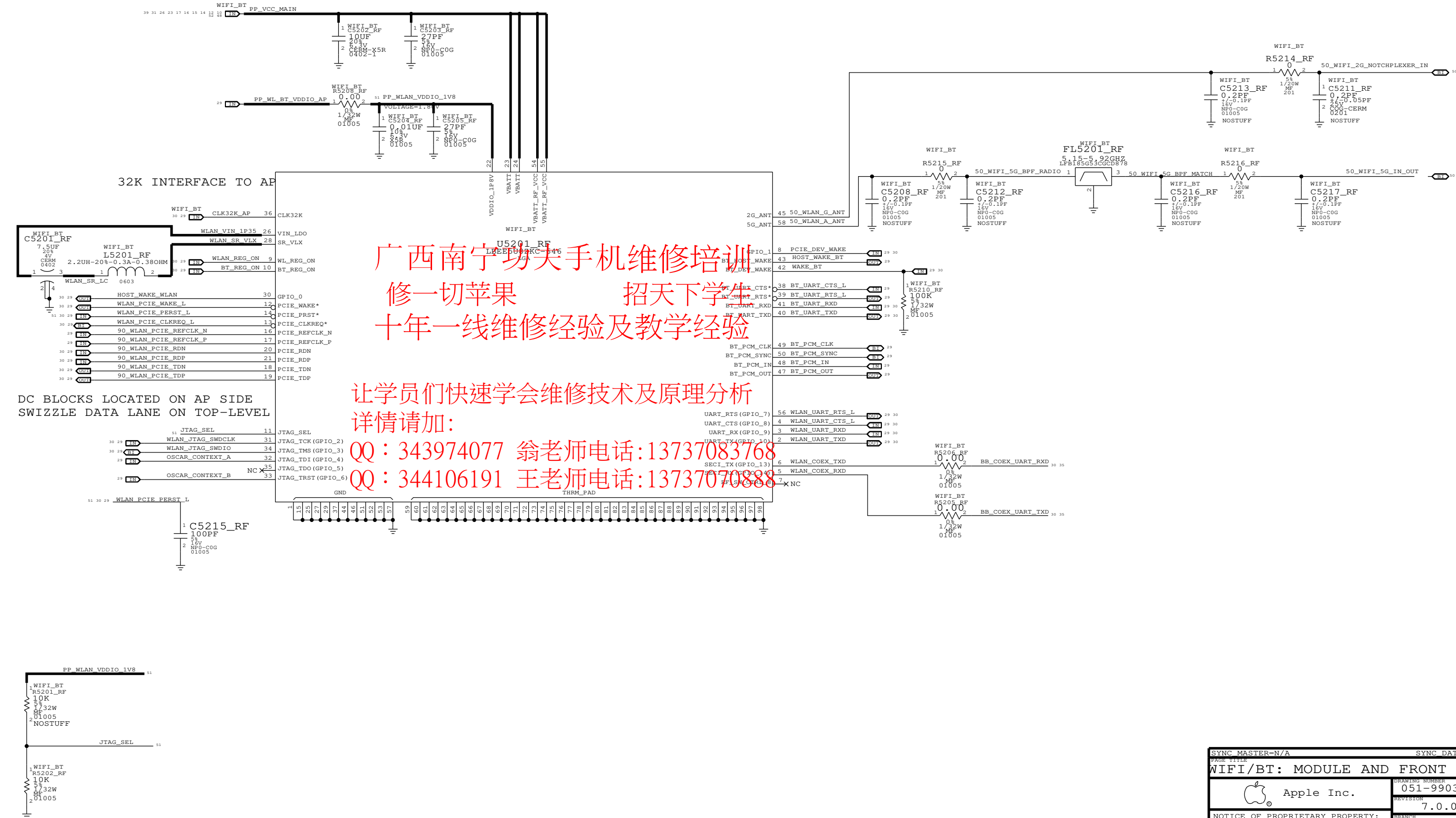

广西南宁功夫手机维修培训
 修一切苹果 招天下学生
 十年一线维修经验及教学经验

让学员们快速学会维修技术及原理分析
 详情请加：
 QQ：343974077 翁老师电话：13737083768
 QQ：344106191 王老师电话：1373708888

DC BLOCKS LOCATED ON AP SIDE
 SWIZZLE DATA LANE ON TOP-LEVEL

MODULE BOOT-STRAPPED TO PCIE INTERNALLY

CONFIDENTIAL AND PROPRIETARY APPLE SYSTEM DESIGN. FOR REFERENCE PURPOSE ONLY - NOT A CHANGE REQUEST

SYNC MASTER=N/A		SYNC DATE=N/A	
PAGE TITLE WIFI/BT: MODULE AND FRONT END			
	Apple Inc.	DRAWING NUMBER 051-9903	SIZE D
NOTICE OF PROPRIETARY PROPERTY: THE INFORMATION CONTAINED HEREIN IS THE PROPRIETARY PROPERTY OF APPLE, INC. THE POSSESSOR AGREES TO THE FOLLOWING: I TO MAINTAIN THIS DOCUMENT IN CONFIDENCE II NOT TO REPRODUCE OR COPY IT III NOT TO REVEAL OR PUBLISH IT IN WHOLE OR PART IV ALL RIGHTS RESERVED		REVISION 7.0.0	BRANCH
		PAGE 52 OF 55	SHEET 51 OF 54

8
7
6
5
4
3
2
1

C2101
R2100
L2102
U2100

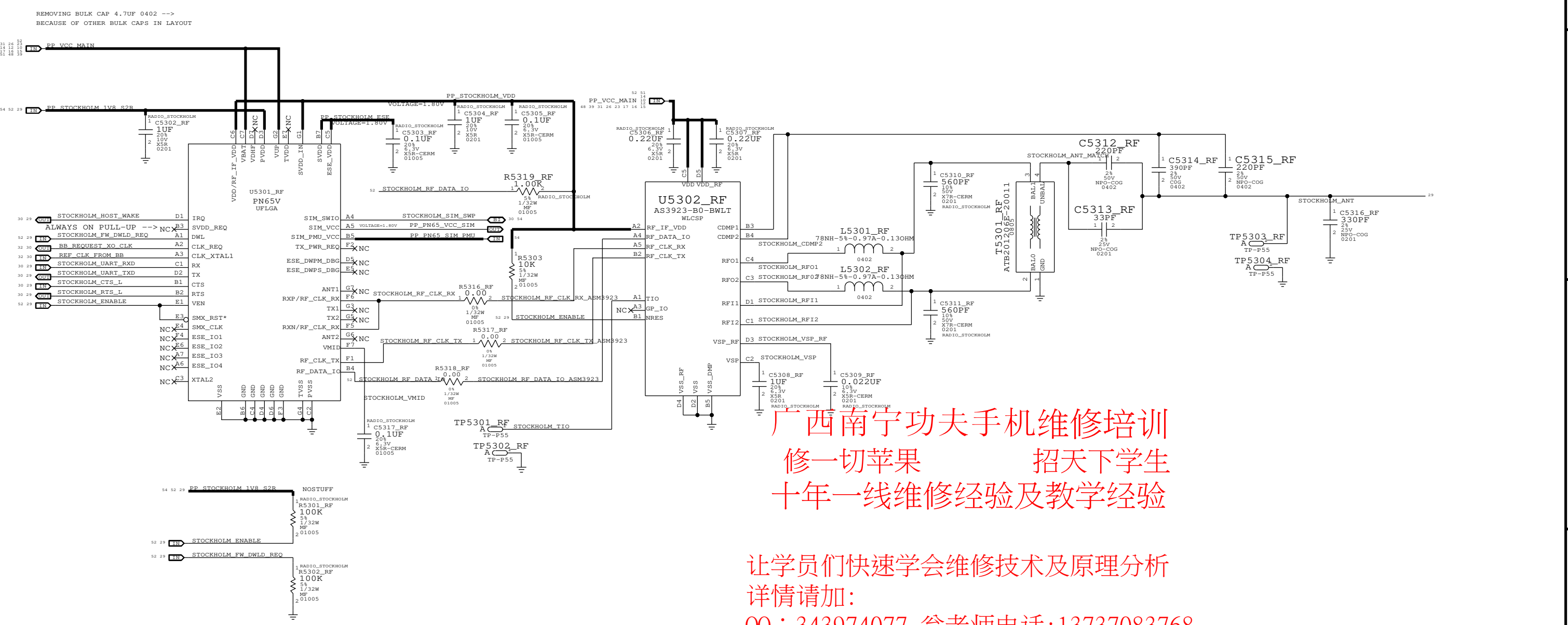

广西南宁功夫手机维修培训
修一切苹果 招天下学生
十年一线维修经验及教学经验

让学员们快速学会维修技术及原理分析
详情请加：
QQ：343974077 翁老师电话：13737083768
QQ：344106191 王老师电话：13737070888

SYNC MASTER=N/A		SYNC DATE=N/A	
PAGE TITLE		DRAWING NUMBER	
Apple Inc.		051-9903 D	
REVISION		7.0.0	
NOTICE OF PROPRIETARY PROPERTY:		BRANCH	
THE INFORMATION CONTAINED HEREIN IS THE PROPRIETARY PROPERTY OF APPLE, INC. THE POSSESSOR AGREES TO THE FOLLOWING:		PAGE	
I TO MAINTAIN THIS DOCUMENT IN CONFIDENCE		53 OF 55	
II NOT TO REPRODUCE OR COPY IT		SHEET	
III NOT TO REVEAL OR PUBLISH IT IN WHOLE OR PART		52 OF 54	
IV ALL RIGHTS RESERVED			

D
C
B
A

D
C
B
A

ON-BOARD JUMPER FLEX

UAT JUMPER

广西南宁功夫手机维修培训
修一切苹果 招天下学生
十年一线维修经验及教学经验

让学员们快速学会维修技术及原理分析
详情请加：
QQ：343974077 翁老师电话：13737083768
QQ：344106191 王老师电话：13737070888

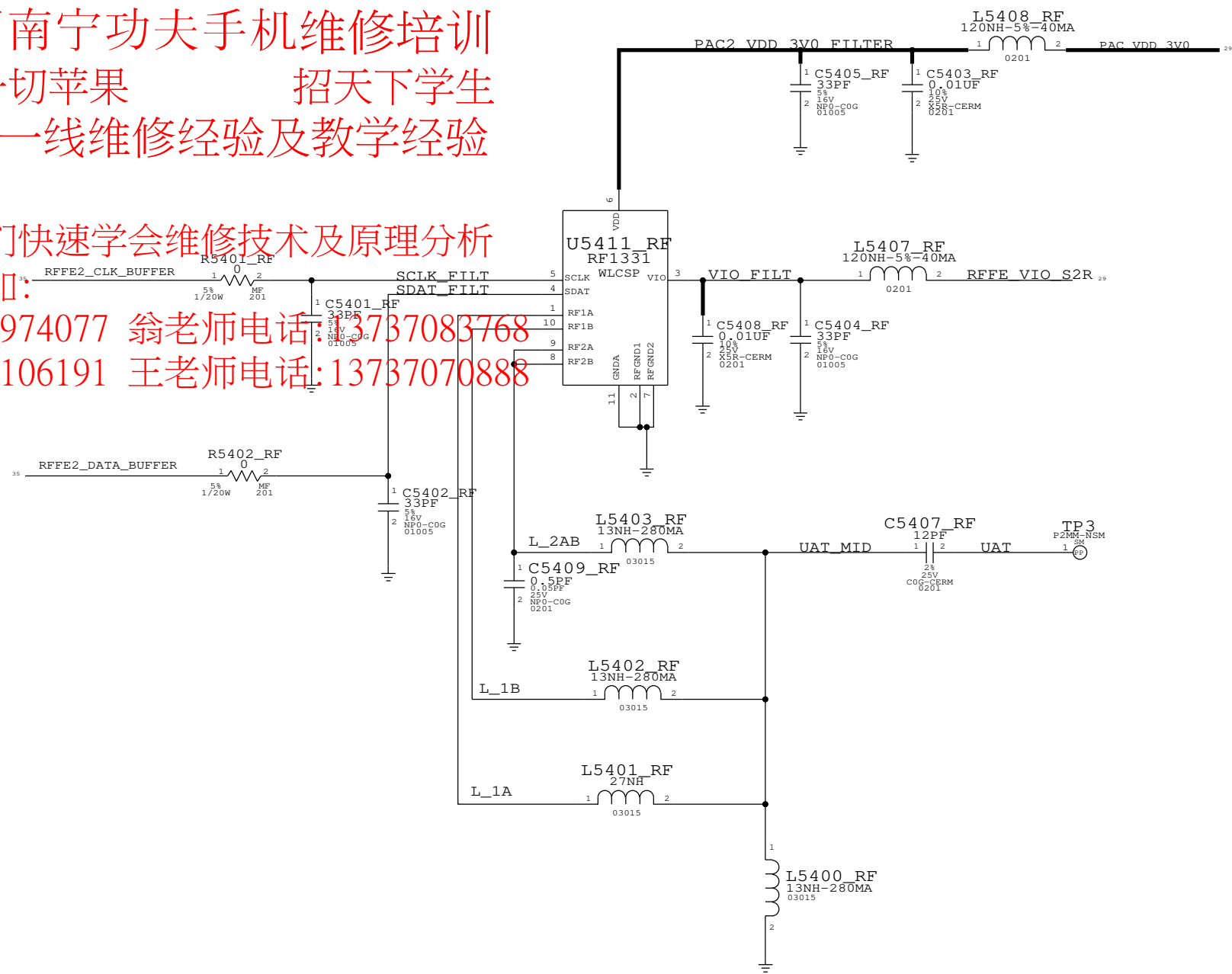

PAGE TITLE JUMPER		
Apple Inc.	DRAWING NUMBER	051-9903
	REVISION	7.0.0
NOTICE OF PROPRIETARY PROPERTY: THE INFORMATION CONTAINED HEREIN IS THE PROPRIETARY PROPERTY OF APPLE, INC. THE POSSESSOR AGREES TO THE FOLLOWING: I TO MAINTAIN THIS DOCUMENT IN CONFIDENCE II NOT TO REPRODUCE OR COPY IT III NOT TO REVEAL OR PUBLISH IT IN WHOLE OR PART IV ALL RIGHTS RESERVED		
PAGE	54 OF 55	
SHEET	53 OF 54	

DSDS

CONFIDENTIAL AND PROPRIETARY APPLE SYSTEM DESIGN. FOR REFERENCE PURPOSES ONLY - NOT A CHANGE REQUEST.

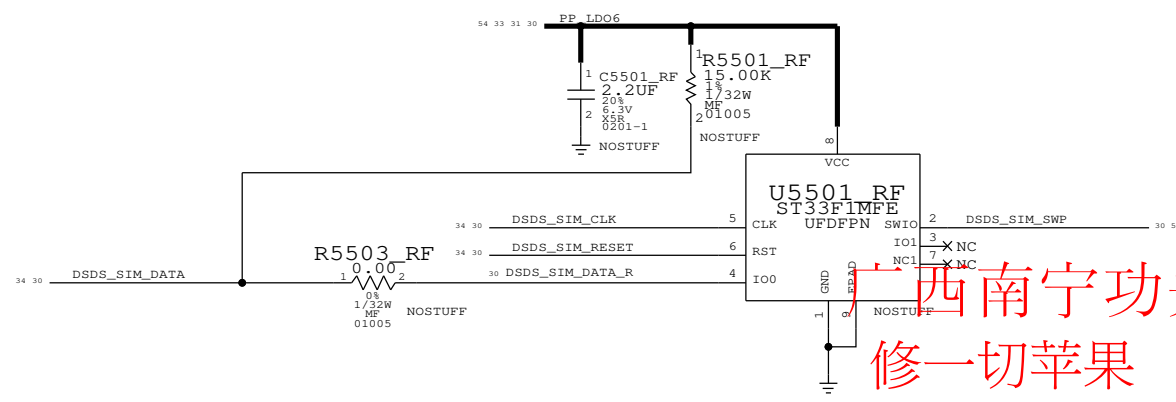

广西南宁功夫手机维修培训
 修一切苹果 招天下学生
 十年一线维修经验及教学经验

让学员们快速学会维修技术及原理分析
 详情请加:

QQ : 343974077 翁老师电话:13737083768

QQ : 344106191 王老师电话:13737070888

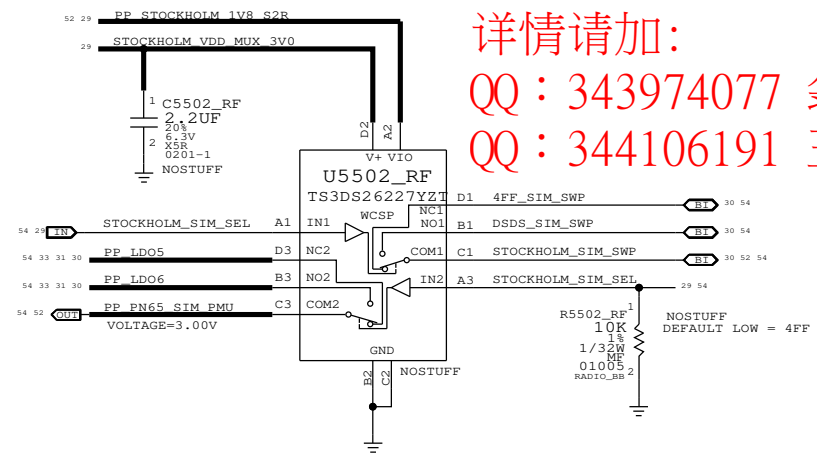
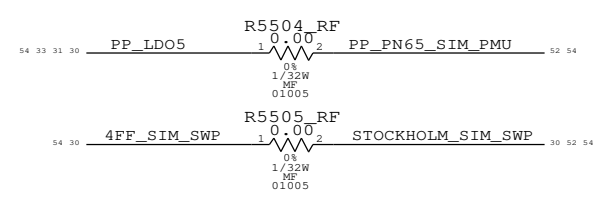

PAGE TITLE		
JUMPER		
Apple Inc.	DRAWING NUMBER	051-9903
	REVISION	7.0.0
NOTICE OF PROPRIETARY PROPERTY:		
THE INFORMATION CONTAINED HEREIN IS THE PROPRIETARY PROPERTY OF APPLE, INC. THE POSSESSOR AGREES TO THE FOLLOWING:		
I TO MAINTAIN THIS DOCUMENT IN CONFIDENCE	BRANCH	
II NOT TO REPRODUCE OR COPY IT	PAGE	55 OF 55
III NOT TO REVEAL OR PUBLISH IT IN WHOLE OR PART	SHEET	54 OF 54
IV ALL RIGHTS RESERVED		